

### Overview

The Auxiliary Power Supply (APS) is a UL 864, 9th Edition listed power supply. It is a 24 Vdc filtered-regulated, and supervised unit that can easily be configured to provide additional notification appliance circuits (NACs) or auxiliary power for Mass Notification/Emergency Communication (MNEC), as well as life safety, security, and access control applications.

The APS contains the circuitry to monitor and charge internal or external batteries. Its steel enclosure has room for up to two 24 ampere-hour batteries. For access control-only applications, the APS can support batteries totaling up to 65 ampere-hours in an external enclosure. The APS has four Class B (convertible to two Class A) NACs. These can be activated in one or two groups from the APS's unique dual input circuits. The APS has a door-mounted AC power indicator LED.

The APS also has room for and can power a number of different modules. These can be Signature AA-30 or AA-50 dual-channel audio amplifiers, SIGA-UIO modules and/or SIGA-RELS. A MN-BKRT3 can also be installed. This bracket can accommodate an MN-NETSW1 Ethernet network switch, an MN-FVPN VoIP module and a MN-COM1S Communications module

The APS is available in 6.5 or 10 ampere models. Each output circuit has a capacity of three amperes; total current draw cannot exceed the unit's rating.

### Features

- Allows for reliable filtered and regulated power to be installed where needed
- Cost effective system expansion
- Provides for Genesis and Enhanced Integrity notification appliance synchronization
- Supports coded output operation
- Self-restoring overcurrent protection
- Multiple signal rates
- Can be cascaded or controlled independently
- Easy field configuration
- On-board diagnostic LEDs identify wiring or internal faults
- Standard GE Security keyed lockable steel cabinet with removable door
- 110 and 230 Vac models available
- Accommodates 18 to 12 AWG wire sizes
- Optional tamper switch
- Dual battery charging rates

The APS meets current UL requirements and is listed as under the following standards:

Standard (CCN)	Description
UL864 9th ed.ition (UOXX)	Fire Alarm Systems
UL636 (ANET, UEHX7)	Holdup Alarm Units and Systems
UL609 (AOTX, AOTX7)	Local Burglar Alarm Units and Systems
UL294 (ALVY, UEHX7)	Access Control Systems
UL365 (APAW, APAW7)	Police Station Connected Burglar Alarm Units and Systems
UL1076 (APOU, APOU7)	Proprietary Burglar Alarm System Units
UL1610 (AMCX)	Central Station Alarm Unit
ULC-S527 (UOXXC)	Control Units, Fire Alarm (Canada)
ULC-S303 (AOTX7)	Local Burglar Alarm Units and Systems (Canada)
ULC-S304 (AMCX7)	Central and Monitoring Station Burglar Alarm Units (Canada)
C22.2 No. 205	Signaling Equipment (Canada)

# Auxiliary Power Supplies

APS6A, APS10A



## Application

The APS provides additional power and circuits for notification appliances and other 24 Vdc loads. It is listed for indoor dry locations and can easily be installed where needed.

Fault conditions are indicated on the on-board diagnostic LEDs, opening the MIBBPS input sense circuit and the trouble relay (if programmed). While this provides indication to the host system, the APS can still be activated upon command. A separate AC Fail contact is available on the APS circuit board, which can be programmed for trouble or AC Fail. There are seven on-board diagnostic LEDs: one for each NAC fault, one for battery fault, one for ground fault, and one for AC power.

The unique dual-input activation circuits of the APS can be activated by any voltage from 6 to 45 VDC (filtered-regulated) or 11 to 33 Vdc (full-wave rectified, unfiltered). The first input circuit can be configured to activate 1-4 of the four possible outputs. The second input circuit can be configured to control circuits 3 and 4. When outputs are configured for auxiliary operation, these circuits can be configured to stay on or automatically deactivate 30 seconds after AC power is lost. This feature makes these circuits ideal for door holder applications. The APS also has a separate 200 mA 24 Vdc output that can be used to power internal activation modules.

APS NACs can be configured for a 3-3-3 temporal or continuous output. California temporal rate outputs are also available on certain models. This makes the APS ideal for applications requiring signaling rates that are not available from the main system.

In addition to the internally generated signal rates, the APS can also be configured to follow the coded signal rate of the main system NACs. This allows for the seamless expansion of existing NACs.

At the top of the steel enclosure, the APS has space and mounting bosses for:

- Up to two SIGA-AA30 or SIGA-AA50 dual-channel audio amplifiers

- One MN-BRKT3 with one MN-NETSW1 Ethernet switch, one MN-FVPN VoIP module, and one MN-COM1S communication module
- One GSA-UIO6 or GSA-UIO6R module motherboard
- Up to two GSA-UIO2R module motherboards
- Up to two GSA-REL releasing modules
- Up to two SIGA MP2L mounting plates modules

The above devices are in addition to the three factory-installed Signature module mounting brackets to the right of the APS circuit board.

## Engineering Specification

Supply, where needed, GE Security APS Series Auxiliary Power Supplies (APS) that are interconnected to and supervised by the main system. The APS shall function as a stand-alone auxiliary power supply with its own fully-supervised battery compliment. The APS battery compliment shall be sized to match the requirements of the main system. The APS shall be capable of supervising and charging batteries having the capacity of 24 ampere-hours for Mass Notification/Emergency Communication (MNEC), life safety and security applications, and the capacity of 65 ampere-hours for access control applications.

The APS shall provide a minimum of four independent, fully supervised Class B circuits that can be field configurable for notification appliance circuits or auxiliary 24 Vdc power circuits. APS NACs shall be convertible to a minimum of two Class A NACs. Each APS output circuit shall be rated at 3 amperes at 24 VDC. Each output circuit shall be provided with automatically restoring overcurrent protection. The APS shall be operable from the main system NAC and/or GE Security Signature Series control modules. APS NACs shall be configurable for continuous, 3-3-3 temporal or optionally, California rate. Fault conditions on the APS shall not impede operation of main system NAC. The APS shall be provided with ground fault detection circuitry and a separate AC fail relay.

## Cabinet Layout

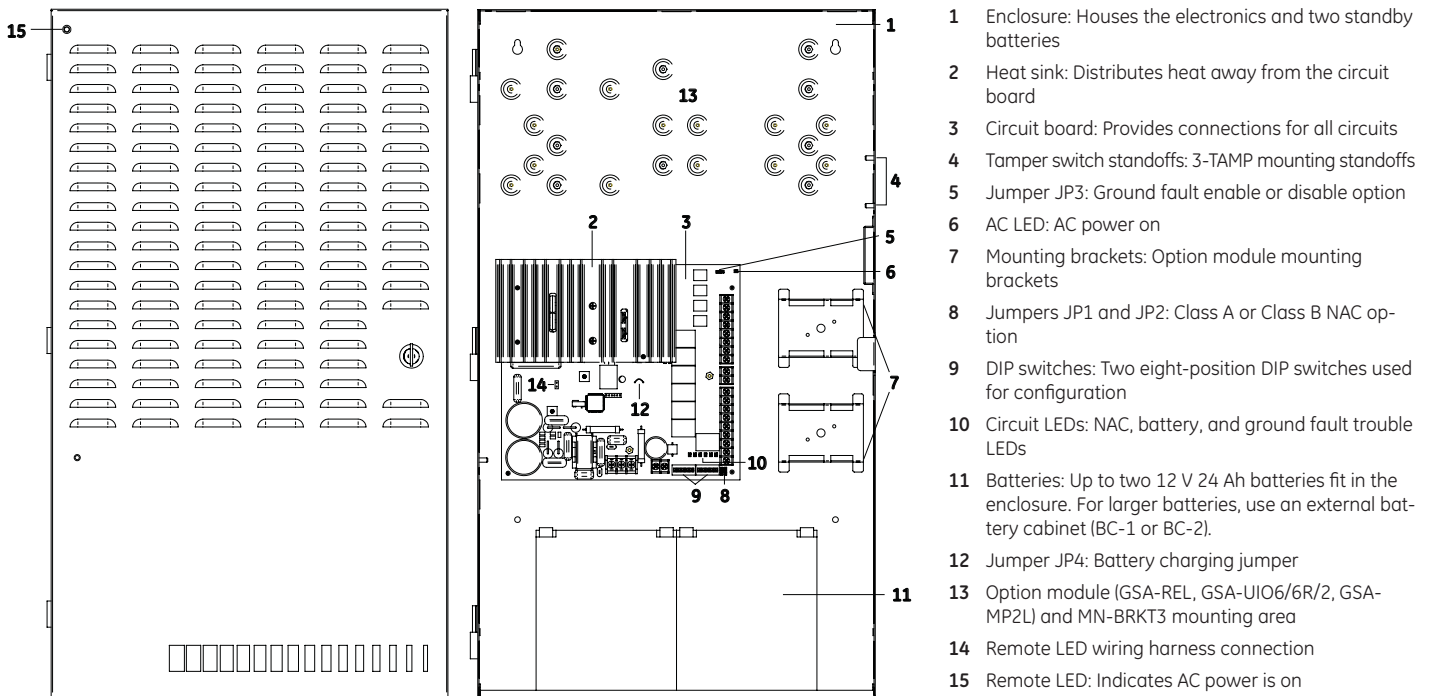

# Typical Wiring

## NAC Class A wiring

Connect a single NAC circuit to one NAC output. Terminate the circuit with a 15 k Ohm EOL resistor.

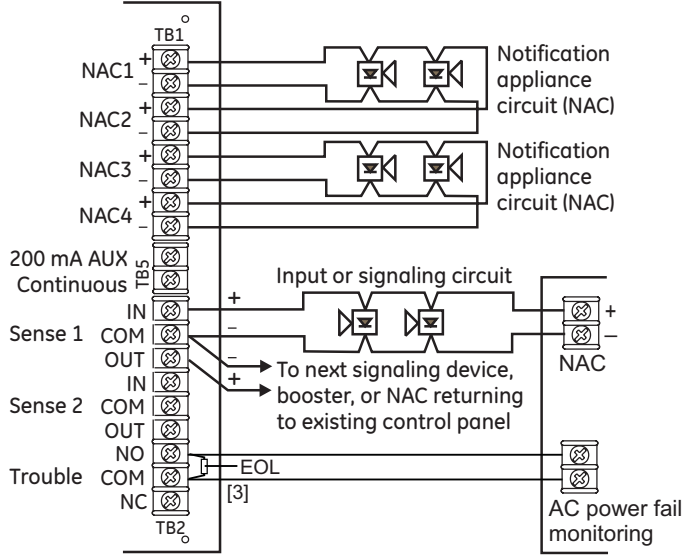

## NAC Class B wiring

Connect one NAC circuit to one NAC output, either NAC1 or NAC3. Terminate the circuit at the NAC2 or NAC4 terminal screw, respectively.

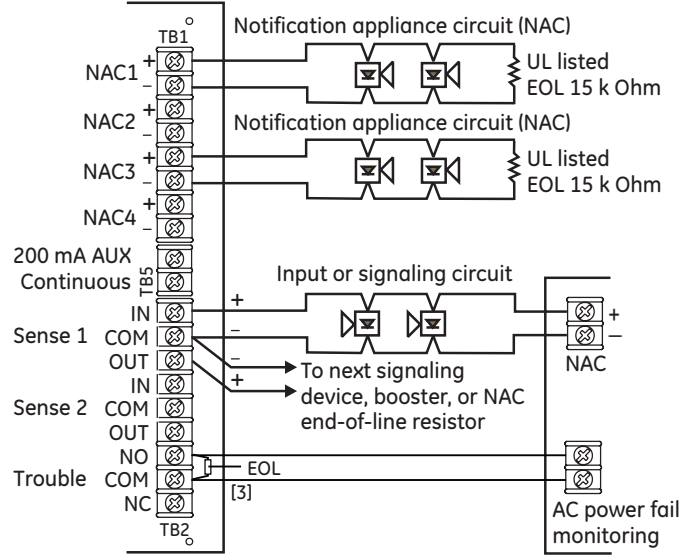

### NAC wiring notes:

1. A trouble on the APS is sensed on the existing control panel's NAC circuit causing a NAC trouble on that panel. This removes the need to separately monitor the trouble contact except for AC power failure (see [3] below).  
In an alarm condition, the APS allows NAC current to move downstream to devices connected to the existing control panel's NAC circuit.
2. Refer to the connected control panel's documentation for more details on NAC wiring.
- [3] The AC power failure panel connection annunciates at the panel but does not report off premises for a predetermined time period in U.S. fire applications.

## Trouble relay wiring with four AUX circuits

When all four NAC/AUX circuits are configured as AUX circuits and DIP switch SW2-6 is ON, a GSA-CT2 module must be used to monitor the sense 1 trouble contacts and the trouble relay.

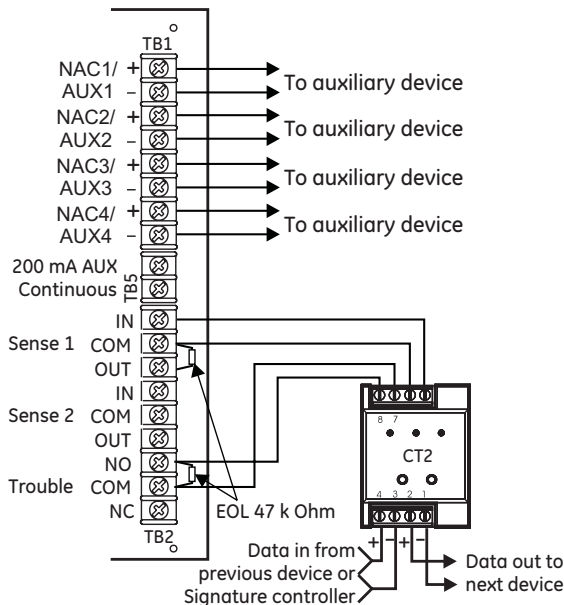

## Dimensions

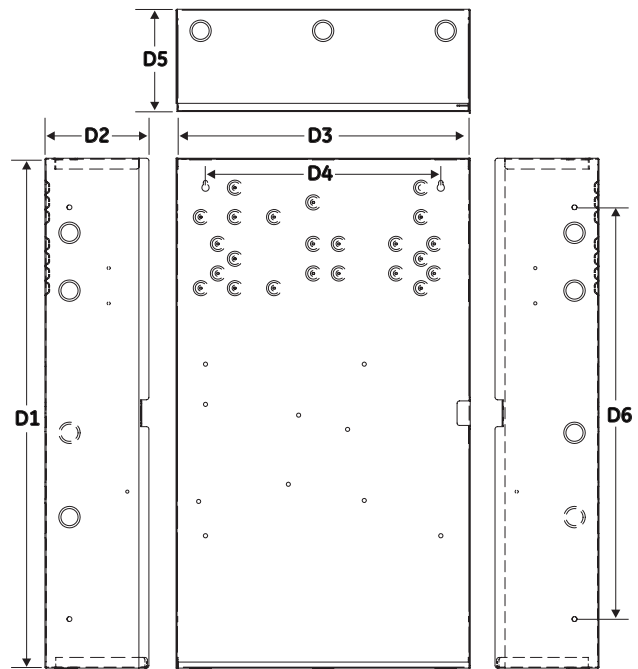

D1	D2	D3	D4	D5	D6
26.0 in (66 cm)	5.3 in (13.5 cm)	15.0 in (38 cm)	12 in (30.5 cm)	5.3 in (13.5 cm)	21.0 in (53.3 cm)

U.S.  
T 888-378-2329  
F 866-503-3996

Canada  
T 519 376 2430  
F 519 376 7258

Asia  
T 852 2907 8108  
F 852 2142 5063

Australia  
T +61 3 9239 1200  
F +61 3 9239 1299

Europe  
T 32 2 725 11 20  
F 32 2 721 86 13

Latin America  
T 305 593 4301  
F 305 593 4300

www.gesecurity.com

© 2009 General Electric Company  
All Rights Reserved

Signature Series is a Trademark  
of GE Security.

## Specifications

Model	6.5 amp APS	10 amp APS
AC Line Voltage	120VAC or 220-240VAC 50/60Hz 390 watts	120VAC or 220-240VAC 50/60Hz 580 watts
Sense voltage (input)	6 to 45 Vdc, 11 to 33 Vrms (FWR and unfiltered DC)	
Sense current (input)	6 mA @ 24 Vdc, 3 mA @ 12 Vdc, 12 mA @ 45 Vdc	
NAC/AUX output voltage	19.1 to 26.85 Vdc	
NAC/AUX output current	3.0 A max. per circuit (10 A or 6.5 A max. total for all NACs) (10 A or 6.5 A max. total for all AUXs) [2]	
NAC/AUX class	Class B or Class A	
Wire size	18 to 12 AWG (0.75 to 2.5 sq mm)	
NAC EOL	UL: 15 k Ohm (P/N EOL-15) ULC: Use P/N EOL-P1 and select the 15 k Ohm resistor	
Auxiliary output (continuous)	1 dedicated 200 mA auxiliary output, not supervised by APS, included in total current	
Common trouble relay	Form C, 1 A, 30 Vdc (resistive)	
Battery requirements [1]	6.5 to 24 Ah for fire and up to 65 Ah for security applications Under 10 Ah, cut JP4. 10 Ah or above, do not cut JP4.	
Battery charger current limit	1.2 A when the battery jumper wire is cut 2.1 A when the battery jumper wire is not cut	
Operating environment	Temperature 32 to 120 °F (0 to 49 °C) Humidity 0 to 93% RH, noncondensing	
Ground fault impedance	10 k Ohm	
Intended installation environment	Indoor-dry	

[1] The maximum battery size the panel can charge is 24 Ah (12V24A or equivalent) for fire and security applications.

[2] The maximum current is 8 amps for auxiliary circuits that operate when the panel is in standby.

## Ordering Information

Catalog Number	Description	Shipping Wt. lb (kg)
APS6A	6.5 Amp Auxiliary Power Supply	
APS6A/230	6.5 Amp Auxiliary Power Supply (220V)	26 (11.8)
APS10A	10 Amp Auxiliary Power Supply	
APS10A/230	10 Amp Auxiliary Power Supply (220V)	

### Related Equipment

MN-BRKT3	MN-FVP series mounting bracket for APS-(6)(10)A power supplies	
12V6A5	12 V, 7.2 Amp Hour Battery, two required	3.4 (1.6)
12V10A	12 V, 10 Amp Hour Battery, two required	9.5 (4.3)
12V17A	12 V, 18 Amp Hour Battery, two required	13 (5.9)
12V24A	12 V, 24 Amp Hour Battery, two required	20 (9.07)
12V40A	12 V, 40 Amp Hour Battery, two required (see notes 1, 2)	32 (14.5)
12V50A	12 V, 50 Amp Hour Battery, two required (see notes 1, 2)	40 (18.14)
12V65A	12 V, 65 Amp Hour Battery, two required (see notes 1, 2)	49 (22.2)
3-TAMP	Tamper switch	1.0 (0.6)
BC-1	Battery Cabinet (up to 2 - 40 Amp Hour Batteries)	58 (26.4)

### Notes

- Requires installation of separate battery cabinet.
- APS supports batteries greater than 24 Amp hours for access control applications only.



imagination at work