

HIKVision IR Speed DOME PTZ Camera User Manual

**DS-2DF7274-A DS-2DF7276-A DS-2DF5284-A
DS-2DF5284-A0DS-2DF5286-A DS-2DF5286-A
DS-2DF7284-A DS-2AF7264-A DS-2AF7268-A**

**IR Speed Dome
Installation Manual**

V1.0.0

UD.6L0201A1032A02

Thank you for purchasing our product. If there are any questions, or requests, please do not hesitate to contact the dealer.

This manual applies to **IR Speed Dome**.

This manual may contain several technical or printing errors, and the content is subject to change without notice. The updates will be added to the new version of this manual. We will readily improve or update the products or procedures described in the manual.

DISCLAIMER STATEMENT

“Underwriters Laboratories Inc. (“UL”) has not tested the performance or reliability of the security or signaling aspects of this product. UL has only tested for fire, shock or casualty hazards as outlined in UL’s Standard(s) for Safety, UL60950-1. UL Certification does not cover the performance or reliability of the security or signaling aspects of this product. UL MAKES NO REPRESENTATIONS, WARRANTIES OR CERTIFICATIONS WHATSOEVER REGARDING THE PERFORMANCE OR RELIABILITY OF ANY SECURITY OR SIGNALING RELATED FUNCTIONS OF THIS PRODUCT.

0203001030406

Regulatory Information

FCC Information

FCC compliance: This equipment has been tested and found to comply with the limits for a digital device, pursuant to part 15 of the FCC Rules. These limits are designed to provide reasonable protection against harmful interference when the equipment is operated in a commercial environment. This equipment generates, uses, and can radiate radio frequency energy and, if not installed and used in accordance with the instruction manual, may cause harmful interference to radio communications. Operation of this equipment in a residential area is likely to cause harmful interference in which case the user will be required to correct the interference at his own expense.

FCC Conditions

This device complies with part 15 of the FCC Rules. Operation is subject to the following two conditions:

1. This device may not cause harmful interference.
2. This device must accept any interference received, including interference that may cause undesired operation.

EU Conformity Statement



This product and - if applicable - the supplied accessories too are marked with "CE" and comply therefore with the applicable harmonized European standards listed under the Low Voltage Directive 2006/95/EC, the EMC Directive 2004/108/EC, the RoHS Directive 2011/65/EU.



2012/19/EU (WEEE directive): Products marked with this symbol cannot be disposed of as unsorted municipal waste in the European Union. For proper recycling, return this product to your local supplier upon the purchase of equivalent new equipment, or dispose of it at designated collection points. For more information see: www.recyclethis.info.



2006/66/EC (battery directive): This product contains a battery that cannot be disposed of as unsorted municipal waste in the European Union. See the product documentation for specific battery information. The battery is marked with this symbol, which may include lettering to indicate cadmium (Cd), lead (Pb), or mercury (Hg). For proper recycling, return the battery to your supplier or to a designated collection point. For more information see: www.recyclethis.info.



Safety Instruction

These instructions are intended to ensure that the user can use the product correctly to avoid danger or property loss.

The precaution measure is divided into ‘Warnings’ and ‘Cautions’:

Warnings: Serious injury or death may be caused if any of these warnings are neglected.

Cautions: Injury or equipment damage may be caused if any of these cautions are neglected.

	
Warnings Follow these safeguards to prevent serious injury or death.	Cautions Follow these precautions to prevent potential injury or material damage.



Warnings

- All the electronic operation should be strictly compliance with the electrical safety regulations, fire prevention regulations and other related regulations in your local region.
- Please use the power adapter, which is provided by normal company. The standard of the power adapter is 24VAC±10% or 12VDC±10% (depending on models). The power consumption cannot be less than the required value.
- Do not connect several devices to one power adapter as adapter overload may cause over-heat or fire hazard.
- Please make sure that the power has been disconnected before you wire, install or dismantle the speed dome.
- When the product is installed on wall or ceiling, the device shall be firmly fixed.
- If smoke, odors or noise rise from the device, turn off the power at once and unplug the power cable, and then please contact the service center.
- If the product does not work properly, please contact your dealer or the nearest service center. Never attempt to disassemble the speed dome yourself. (We shall not assume any responsibility for problems caused by unauthorized repair or maintenance.)



Cautions

- Do not drop the dome or subject it to physical shock, and do not expose it to high electromagnetism radiation. Avoid the equipment installation on vibrations surface or places subject to shock (ignorance can cause equipment damage).
- Do not place the dome in extremely hot, cold, dusty or damp locations, otherwise fire or electrical shock will occur. The operating temperature should be -30°C ~ 65°C.
- The dome cover for indoor use shall be kept from rain and moisture.
- Exposing the equipment to direct sun light, low ventilation or heat source such as heater or

radiator is forbidden (ignorance can cause fire danger).

- Do not aim the speed dome at the sun or extra bright places. A blooming or smear may occur otherwise (which is not a malfunction however), and affecting the endurance of sensor at the same time.
- Please use the provided glove when open up the dome cover, avoid direct contact with the dome cover, because the acidic sweat of the fingers may erode the surface coating of the dome cover.
- Please use a soft and dry cloth when clean inside and outside surfaces of the dome cover, do not use alkaline detergents.
- Do not stare at infrared LED closely to avoid hurting your eyes when the infrared lights are on.
- Please keep all wrappers after unpack them for future use. In case of any failure occurred, you need to return the speed dome to the factory with the original wrapper. Transportation without the original wrapper may result in damage on the speed dome and lead to additional costs.

Table of Contents

Chapter 1	Installation.....	6
1.1	Installing the IR Speed Dome	6
1.2	Connecting the Cables.....	8
1.3	DIP Switch Settings.....	8
1.3.1	<i>Address Settings</i>	9
1.3.2	<i>Baudrate Settings</i>	11
1.3.3	<i>Protocol Settings</i>	12
1.3.4	<i>Communication Mode Settings</i>	12
1.3.5	<i>Terminal Resistor Settings</i>	12
1.4	Alarm Input and Output Connection.....	13
1.5	Power Cable Requirement	13
Chapter 2	Mount Dimension.....	14
2.1	Wall Mount	14
2.2	Corner Adapter.....	15
2.3	Pole Adapter.....	16
2.4	Pendant Mount	17
Chapter 3	Mounting Applications	18
3.1	Wall Mounting Applications	18
3.1.1	<i>Components</i>	18
3.1.2	<i>Wall Mounting</i>	19
3.2	Corner Mounting Applications	20
3.2.1	<i>Components</i>	20
3.2.2	<i>Corner Mounting</i>	21
3.3	Pole Mounting Applications	22
3.3.1	<i>Components</i>	22
3.3.2	<i>Pole Mounting</i>	24
3.4	Pendant Mounting Applications.....	26
3.4.1	<i>Components</i>	26
3.4.2	<i>Pendant Mounting</i>	26
Appendix		29
	Appendix 1 Lightning & Surge Protection.....	29
	Appendix 2 Waterproof	33
	Appendix 3 Bubble Maintenance	35
	Appendix 4 RS485 Bus Connection.....	36
	Appendix 5 24VAC Wire Gauge & Transmission Distance	39
	Appendix 6 Wire Gauge Standards.....	40

Chapter 1 Installation

Before you start:

Check the package contents and make sure that the device in the package is in good condition and all the assembly parts are included.

Note: Do not drag the waterproof cables as shown in Figure 1-1, otherwise the waterproof performance is affected.

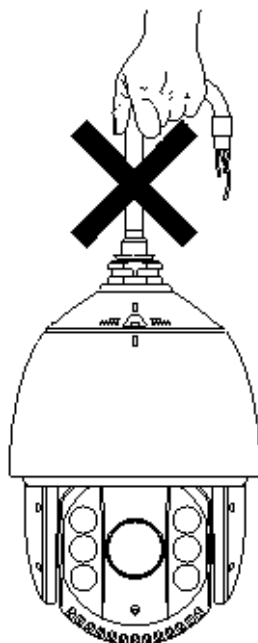

Figure 1-1 Do not Drag the Cables

1.1 Installing the IR Speed Dome

Before you start:

- Check the package contents and make sure that the device in the package is in good condition and all the assembly parts are included.
- Please make sure the wall is strong enough to withstand more than 8 times the weight of the dome and the mount.
- For cement wall, you need to use the expansion screw to fix the mount.
- The long-arm wall mount is taken as the example for following mounting steps.

Steps:

1. Remove the protective sticker from the dome drive.

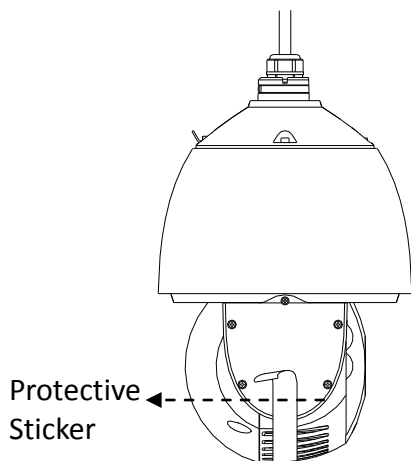

Figure 1-2 Protective Sticker

2. Drill 4 screw holes in the wall according to the holes of the mount.
3. Fix the wall mount to the wall with the M8 expansion screws.

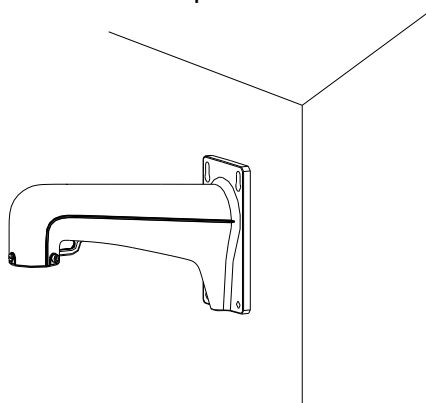

Figure 1-3 Fix the Mount

4. Install the speed dome to the mount.
 - 1). Hang the safety rope to the speed dome and then hook to the mount as shown in Figure 1-4.
 - 2). Route the cables of the speed dome through the wall mount.
 - 3). Connect the corresponding video/power/RS-485 cables.
 - 4). Loosen the two lock screws on the wall mount.
 - 5). Install the speed dome to the mount, and secure the speed dome by rotating the speed dome clockwise.
 - 6). Fasten the two lock screws with the Allen wrench.

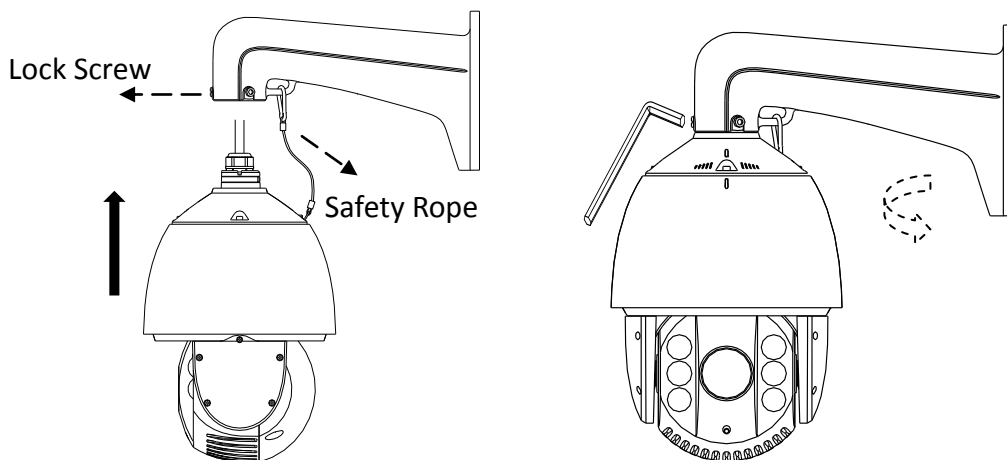

Figure 1-4 Secure the Speed Dome

1.2 Connecting the Cables

Before you start:

Please make sure the power of the dome is off before connecting the cables.

- Choose the video cable according to the transmission length. The video should meet the least demands as: 75Ω resistance; 100% copper core conducting wire; 95% weaving copper shield.
- RS485 communication cable, please refer to Appendix 4
- 24V AC power cable, please refer to Appendix 5

The cable interfaces of speed dome are shown in the following figures. Please refer to the following figure for connecting the RS-485, power and video cables.

As shown in the following figures, the label ① instructs you to connect the power cables. The label ② and ③ instruct you to connect the RS-485 cables.

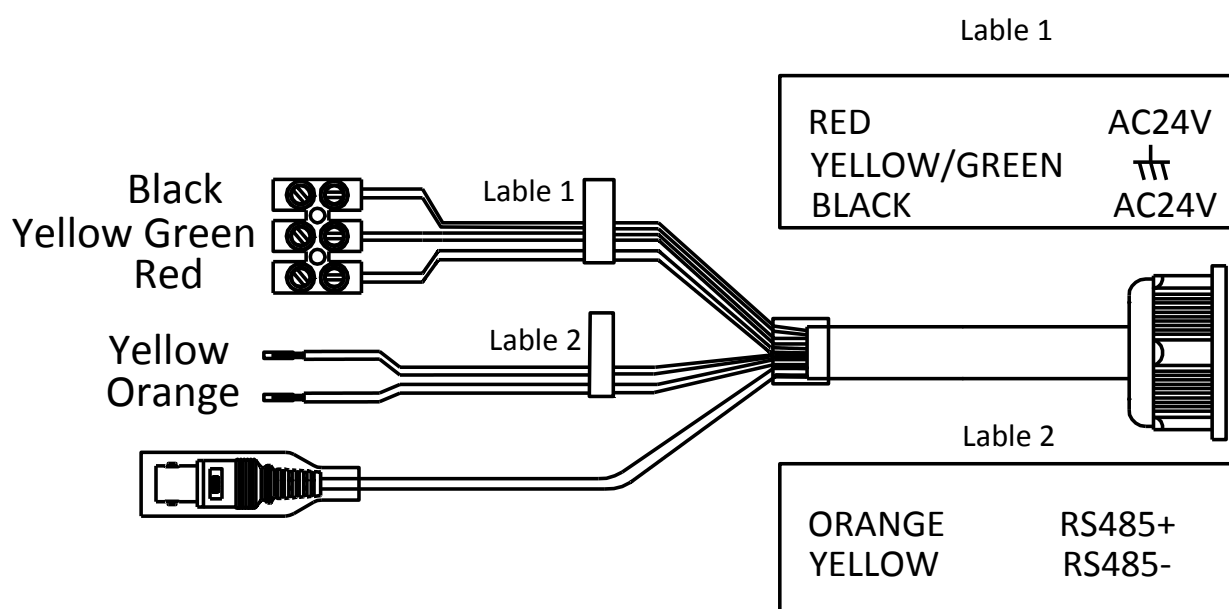

Figure 1-5 IR Speed Dome

1.3 DIP Switch Settings

Two DIP switches *SW1* and *SW2* are for setting the speed dome address, baudrate, protocol, etc., with value ON=1 and OFF=0. The switch label is on the back of the SWITCH cover as shown in Figure 1-6.

Each number of the switch represents a DIP value, ranging from 1 to 8 for the lowest to highest. Please refer to *Section 1.3.1* to *1.3.2* for detailed settings.

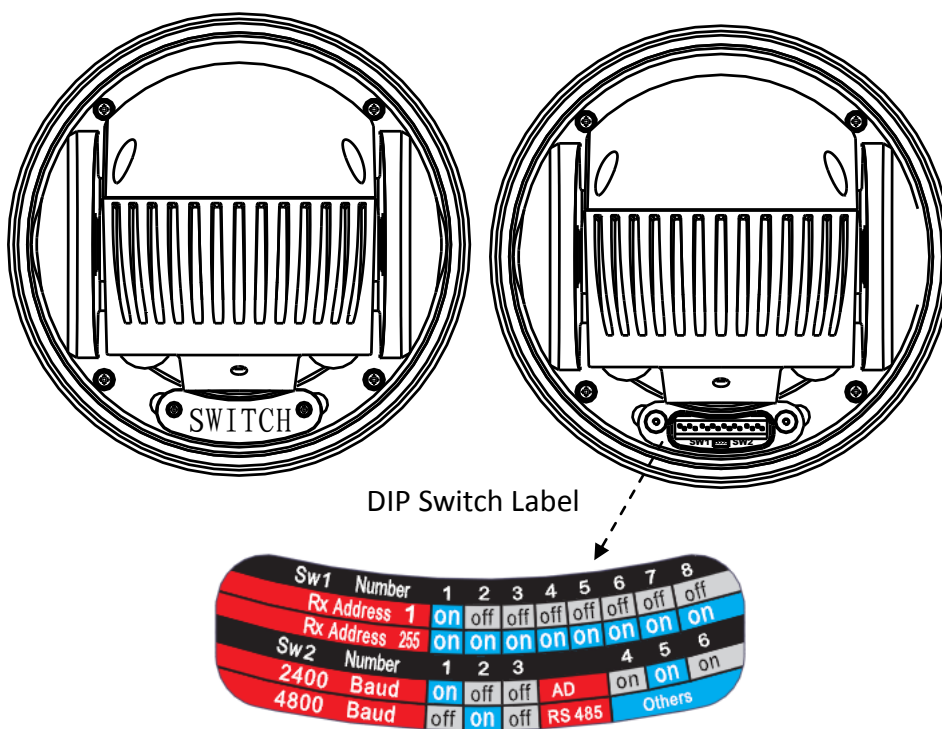

Figure 1-6 Label of DIP Switch

Note: The default dome address is 0; the default baudrate is 2400; and the default value of the 120Ω terminator is OFF.

1.3.1 Address Settings

The SW1 switch is used for setting the address of speed dome. You can refer to Table 1-1 and Table 1-2 for details of setting the speed dome address to a specific number.

Table 1-1 Set the Dome Address

Dome Address	SW1 Settings	1	2	3	4	5	6	7	8
0	SW1	OFF	OFF	OFF	OFF	OFF	OFF	OFF	OFF
1	SW1	ON	OFF	OFF	OFF	OFF	OFF	OFF	OFF
-	-	-	-	-	-	-	-	-	-
255	SW1	ON	ON	ON	ON	ON	ON	ON	ON

Refer to the following table for more address settings:

Table 1-2 Set the Dome Address from 0 to 71

	DIP Switch SW1 Settings							
Address	1	2	3	4	5	6	7	8

	DIP Switch SW1 Settings							
0	OFF	OFF	OFF	OFF	OFF	OFF	OFF	OFF
1	ON	OFF	OFF	OFF	OFF	OFF	OFF	OFF
2	OFF	ON	OFF	OFF	OFF	OFF	OFF	OFF
3	ON	ON	OFF	OFF	OFF	OFF	OFF	OFF
4	OFF	OFF	ON	OFF	OFF	OFF	OFF	OFF
5	ON	OFF	ON	OFF	OFF	OFF	OFF	OFF
6	OFF	ON	ON	OFF	OFF	OFF	OFF	OFF
7	ON	ON	ON	OFF	OFF	OFF	OFF	OFF
8	OFF	OFF	OFF	ON	OFF	OFF	OFF	OFF
9	ON	OFF	OFF	ON	OFF	OFF	OFF	OFF
10	OFF	ON	OFF	ON	OFF	OFF	OFF	OFF
11	ON	ON	OFF	ON	OFF	OFF	OFF	OFF
12	OFF	OFF	ON	ON	OFF	OFF	OFF	OFF
13	ON	OFF	ON	ON	OFF	OFF	OFF	OFF
14	OFF	ON	ON	ON	OFF	OFF	OFF	OFF
15	ON	ON	ON	ON	OFF	OFF	OFF	OFF
16	OFF	OFF	OFF	OFF	ON	OFF	OFF	OFF
17	ON	OFF	OFF	OFF	ON	OFF	OFF	OFF
18	OFF	ON	OFF	OFF	ON	OFF	OFF	OFF
19	ON	ON	OFF	OFF	ON	OFF	OFF	OFF
20	OFF	OFF	ON	OFF	ON	OFF	OFF	OFF
21	ON	OFF	ON	OFF	ON	OFF	OFF	OFF
22	OFF	ON	ON	OFF	ON	OFF	OFF	OFF
23	ON	ON	ON	OFF	ON	OFF	OFF	OFF
24	OFF	OFF	OFF	ON	ON	OFF	OFF	OFF
25	ON	OFF	OFF	ON	ON	OFF	OFF	OFF
26	OFF	ON	OFF	ON	ON	OFF	OFF	OFF
27	ON	ON	OFF	ON	ON	OFF	OFF	OFF
28	OFF	OFF	ON	ON	ON	OFF	OFF	OFF
29	ON	OFF	ON	ON	ON	OFF	OFF	OFF
30	OFF	ON	ON	ON	ON	OFF	OFF	OFF
31	ON	ON	ON	ON	ON	OFF	OFF	OFF
32	OFF	OFF	OFF	OFF	OFF	ON	OFF	OFF
33	ON	OFF	OFF	OFF	OFF	ON	OFF	OFF
34	OFF	ON	OFF	OFF	OFF	ON	OFF	OFF
35	ON	ON	OFF	OFF	OFF	ON	OFF	OFF
36	OFF	OFF	ON	OFF	OFF	ON	OFF	OFF
37	ON	OFF	ON	OFF	OFF	ON	OFF	OFF
38	OFF	ON	ON	OFF	OFF	ON	OFF	OFF
39	ON	ON	ON	OFF	OFF	ON	OFF	OFF
40	OFF	OFF	OFF	ON	OFF	ON	OFF	OFF
41	ON	OFF	OFF	ON	OFF	ON	OFF	OFF

	DIP Switch SW1 Settings							
42	OFF	ON	OFF	ON	OFF	ON	OFF	OFF
43	ON	ON	OFF	ON	OFF	ON	OFF	OFF
44	OFF	OFF	ON	ON	OFF	ON	OFF	OFF
45	ON	OFF	ON	ON	OFF	ON	OFF	OFF
46	OFF	ON	ON	ON	OFF	ON	OFF	OFF
47	ON	ON	ON	ON	OFF	ON	OFF	OFF
48	OFF	OFF	OFF	OFF	ON	ON	OFF	OFF
49	ON	OFF	OFF	OFF	ON	ON	OFF	OFF
50	OFF	ON	OFF	OFF	ON	ON	OFF	OFF
51	ON	ON	OFF	OFF	ON	ON	OFF	OFF
52	OFF	OFF	ON	OFF	ON	ON	OFF	OFF
53	ON	OFF	ON	OFF	ON	ON	OFF	OFF
54	OFF	ON	ON	OFF	ON	ON	OFF	OFF
55	ON	ON	ON	OFF	ON	ON	OFF	OFF
56	OFF	OFF	OFF	ON	ON	ON	OFF	OFF
57	ON	OFF	OFF	ON	ON	ON	OFF	OFF
58	OFF	ON	OFF	ON	ON	ON	OFF	OFF
59	ON	ON	OFF	ON	ON	ON	OFF	OFF
60	OFF	OFF	ON	ON	ON	ON	OFF	OFF
61	ON	OFF	ON	ON	ON	ON	OFF	OFF
62	OFF	ON	ON	ON	ON	ON	OFF	OFF
63	ON	ON	ON	ON	ON	ON	OFF	OFF
64	OFF	OFF	OFF	OFF	OFF	OFF	ON	OFF
65	ON	OFF	OFF	OFF	OFF	OFF	ON	OFF
66	OFF	ON	OFF	OFF	OFF	OFF	ON	OFF
67	ON	ON	OFF	OFF	OFF	OFF	ON	OFF
68	OFF	OFF	ON	OFF	OFF	OFF	ON	OFF
69	ON	OFF	ON	OFF	OFF	OFF	ON	OFF
70	OFF	ON	ON	OFF	OFF	OFF	ON	OFF
71	ON	ON	ON	OFF	OFF	OFF	ON	OFF

1.3.2 Baudrate Settings

The No. 1, 2 and 3 of SW2 switch are for setting the baudrate of the speed dome, standing for 2400bps, 4800bps and 9600bps respectively. The baudrate will be set as 2400bps by default if it is out of this range. Refer to the following table:

Table 1-3 Set the Baudrate of the Dome

DIP Switch SW2-Baudrate Settings				
Baudrate	Figure	1	2	3
2400		ON	OFF	OFF

DIP Switch SW2-Baudrate Settings					
4800	SW2		OFF	ON	OFF
9600	SW2		ON	ON	OFF

1.3.3 Protocol Settings

The No. 4, 5 and 6 of SW2 switch are for setting the communication protocols of the dome. Refer to the following table:

Table 1-4 Set the Protocol of the Dome

DIP Switch SW2-Protocol Settings				
Protocol	Figure	4	5	6
AD Manchester	SW 2	ON	ON	ON
Others	Self-adaptive			

Notes:

- The speed dome is self-adaptive to PELCO-D, PELCO-P and private protocol which cannot set by the DIP switches.
- Network speed dome model does not support Manchester Code protocol.

1.3.4 Communication Mode Settings

The No. 7 of SW2 switch is for setting the RS485 communication mode of the dome to simplex or half-duplex.

Table 1-5 Set Communication Mode of the Dome

DIP Switch SW2-Simplex/Half-duplex Settings		
Description	Figure	7
Simplex	SW2	OFF
Half-duplex	SW2	ON

1.3.5 Terminal Resistor Settings

The No. 8 of SW2 switch is used for turning on/off the 120Ω terminal resistor.

Table 1-6 Set Terminal Resistor

Switch Number	8
Description	

Turn on the resistor	OFF
Turn off the resistor	ON

1.4 Alarm Input and Output Connection

The network speed dome can be connected with alarm inputs (0~5VDC) and alarm outputs. Refer to the following diagrams for alarm output:

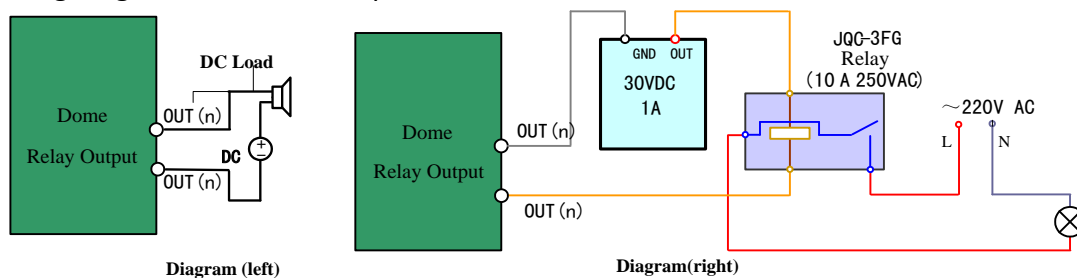

Figure 1-7 Alarm Out Connections

The alarm provides the relay output (no voltage), and the external power supply is required when it connects to the alarm device.

- For DC power supply (left diagram), the input voltage must be no more than 30VDC, 1A.
- For AC power supply, the external relay must be used (right diagram) to prevent damages to the speed dome and avoid risk of electric shock.

1.5 Power Cable Requirement

When the speed dome uses standard AC power supply, the power cable should meet the demand. The formula of the cross-section S (mm^2) and the maximum transmission distance L (m) of the bare wire is as follows:

$$L=50*S \text{ (analog speed dome)}$$

$$L=40*S \text{ (network speed dome)}$$

Example:

For the analog speed dome, the cross-section of the cable is 1mm^2 and the transmission distance is less than 50m.

According to the **Appendix 5 24VAC Wire Gauge Standards**, for example, the American wire gauge 18, the transmission distance should be $0.7854*50=39.27\text{m}$.

Chapter 2 Mount Dimension

Note: Not all of the mounts are listed in this manual. Please refer to the specification manual.

2.1 Wall Mount

You can use the wall mount with corner adapter or pole adapter according to different installation environments.

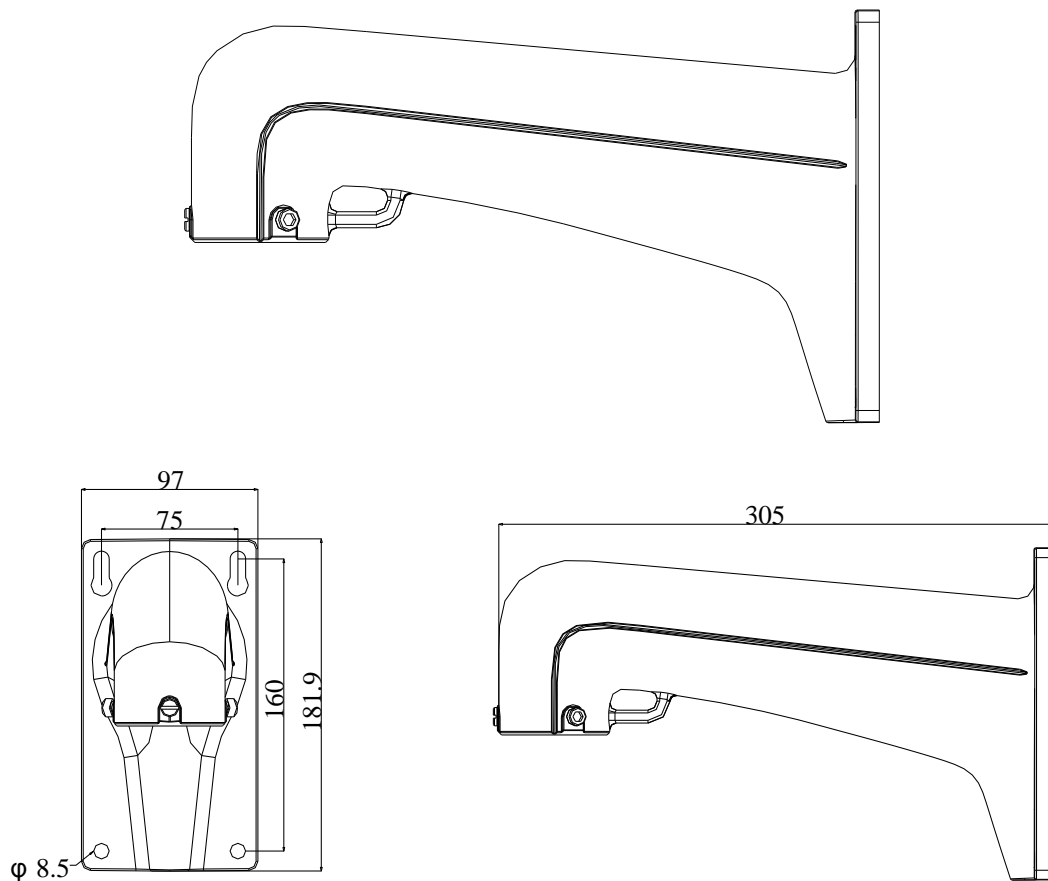

Figure 2-1 Wall Mount

2.2 Corner Adapter

A corner adapter has to be used together with a wall mount for corner mounting applications.

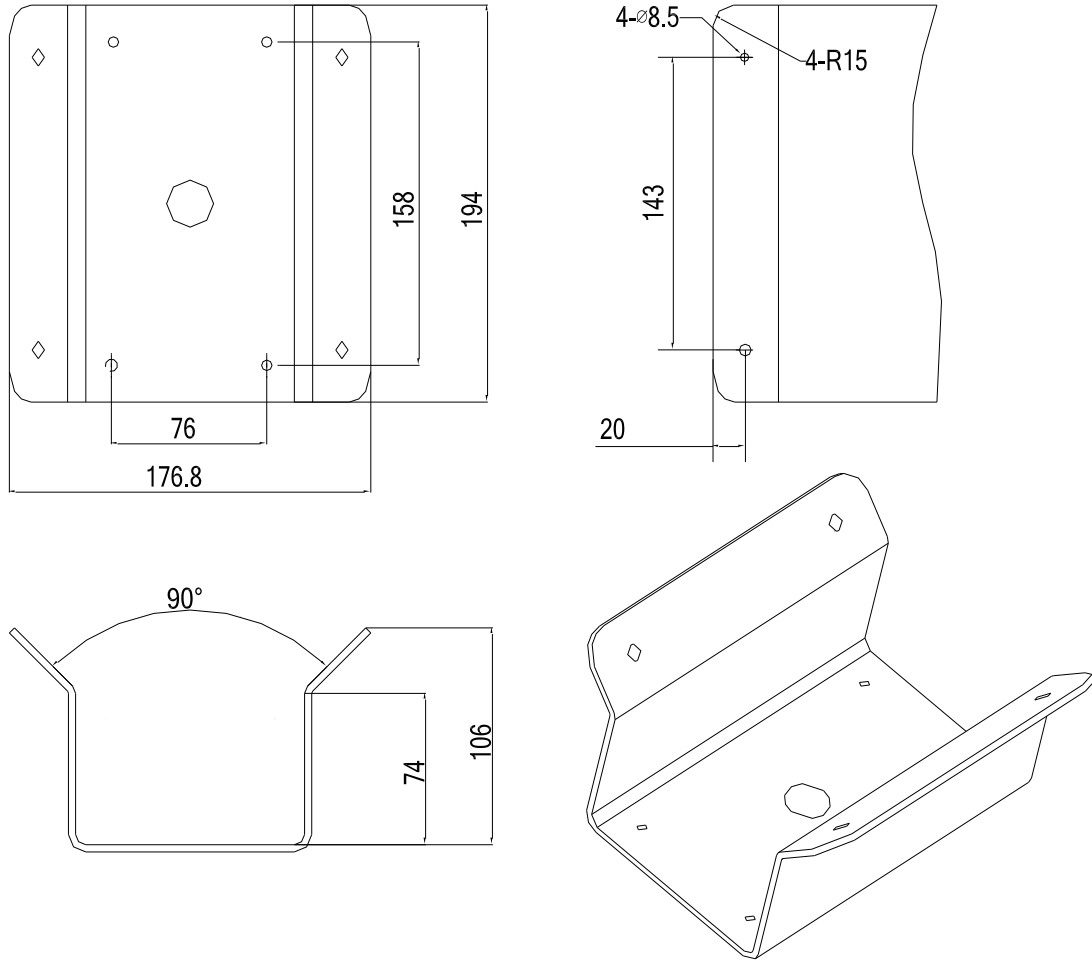

Figure 2-2 Corner Adapter

2.3 Pole Adapter

A pole adapter has to be used together with a wall mount for pole mounting applications.

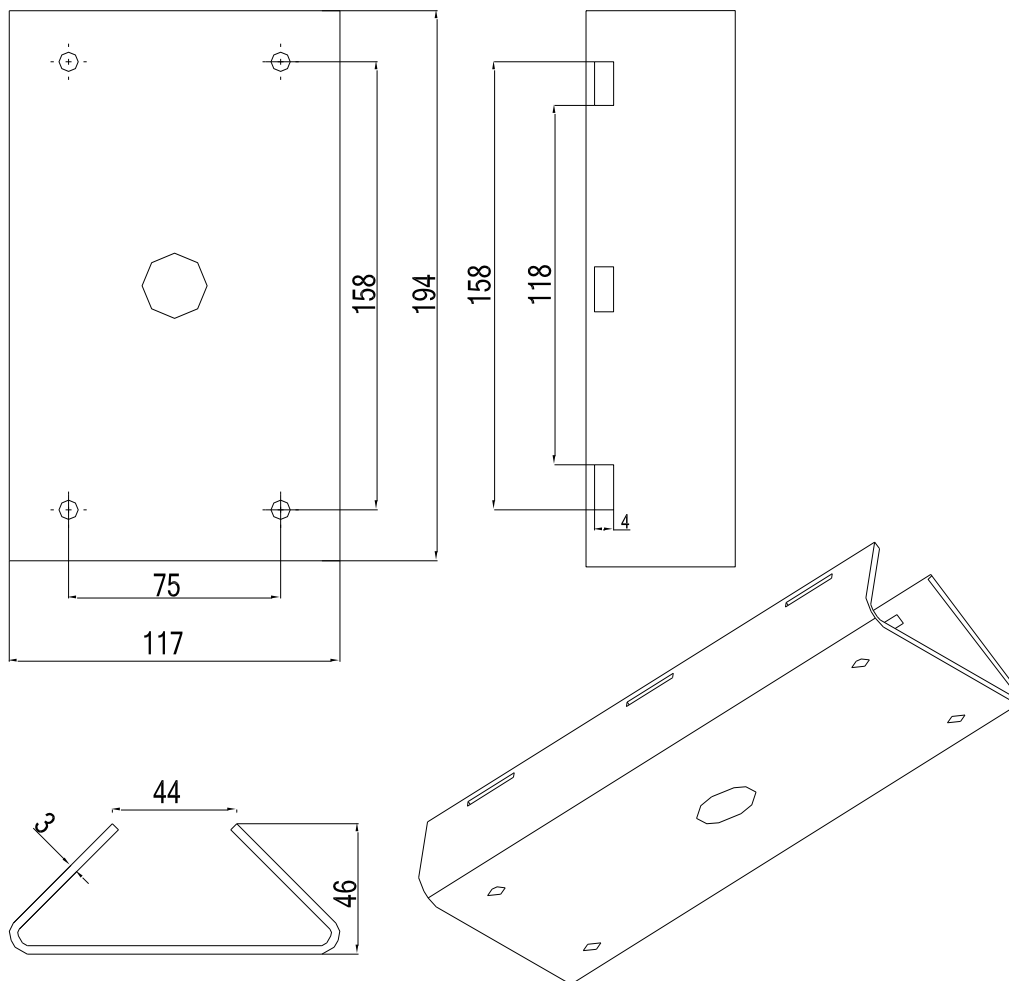

Figure 2-3 Pole Adapter

2.4 Pendant Mount

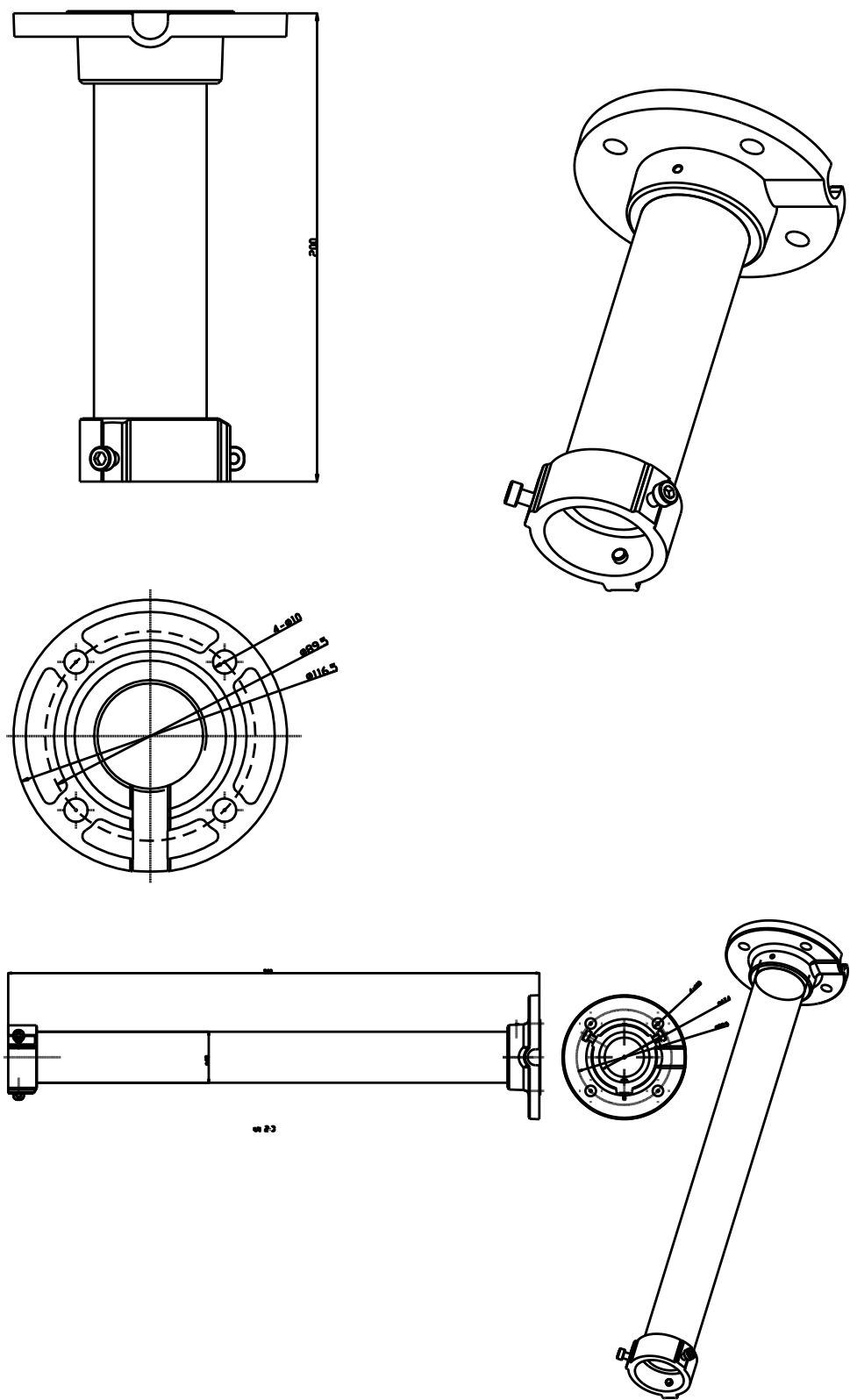

Figure 2-4 Pendant Mount

Chapter 3 Mounting Applications

Before you start:

- For cement wall, you need to use the expansion screw to fix the mount. The mounting hole of the expansion pipe on the wall should align with the mounting hole on the mount.
- For wooden wall, you can just use the self-tapping screw to fix the mount.
- The wall must be thick enough to install the expansion screws.
- Please make sure that the wall is strong enough to withstand more than 8 times the weight of the dome and the mount.

3.1 Wall Mounting Applications

3.1.1 Components

- **Wall Mount**

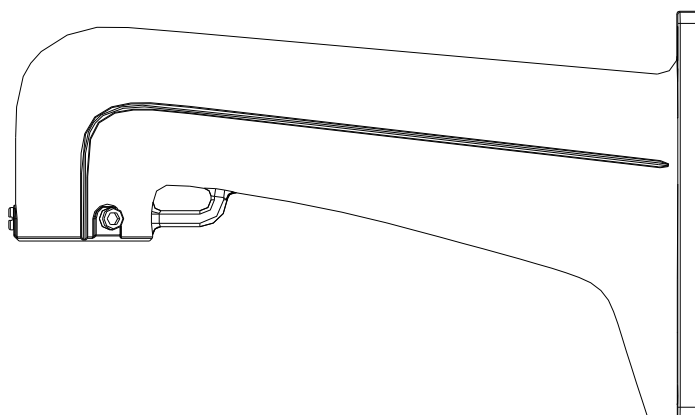

Figure 3-1 Wall Mount

- **Mounting Accessories**

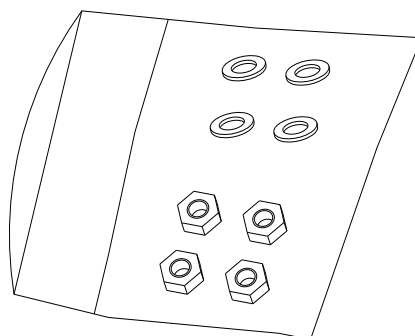

Figure 3-2 Nuts and Flat Washers

3.1.2 Wall Mounting

Steps:

1. Drill 4 screw holes in the wall according to the holes of the mount, and then insert M6 expansion screws (not supplied) into the mounting holes.
2. Attach the gasket then wall mount to the wall by aligning the 4 screw holes of the mount with expansion screws on the wall.
3. Secure the wall mount with 4 hex nuts and washers.

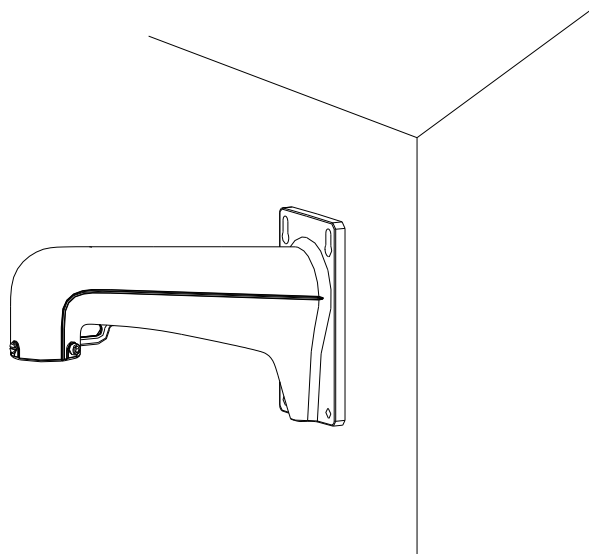

Figure 3-3 Drill Screw Holes

4. Install the speed dome to the mount. Please refer to *Section 1.1 Installation and Cabling* for installation details.

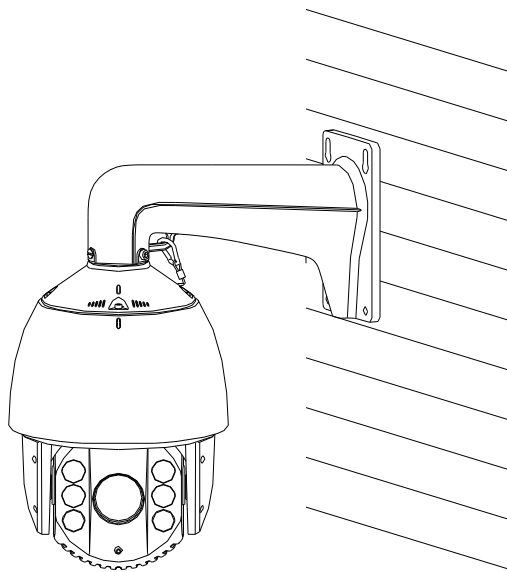

Figure 3-4 Finish the Installation

3.2 Corner Mounting Applications

Before you start:

The corner mounting is applicable to the indoor/outdoor 90° solid corner construction.

3.2.1 Components

- **Wall Mount**

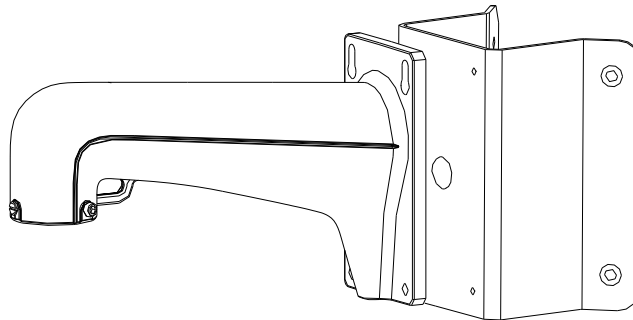

Figure 3-5 Wall Mount

- **Corner Adapter**

A corner adapter has to be used together with a wall mount for corner mounting applications.

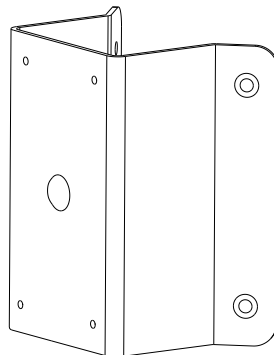

Figure 3-6 Corner Adapter

- **Mounting Accessories**

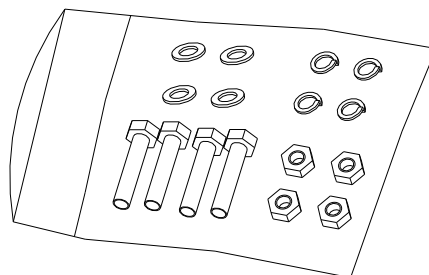

Figure 3-7 Hex Screws (M8×30), Nuts, Spring Washers and Flat Washers

3.2.2 Corner Mounting

1. Install the corner adapter.

Steps:

- (1) Drill four holes in the corner according to the screw holes of the corner adapter, and then insert M8 expansion screws (not supplied) into the holes.
- (2) Pull the power line, video cable and control line through the center hole of the corner adapter.
- (3) Attach the corner adapter to the corner by aligning the 4 screw holes of the corner adapter with expansion screws on the corner.
- (4) Secure the corner adapter to the corner with the nuts and washers to tighten the four expansion screws.

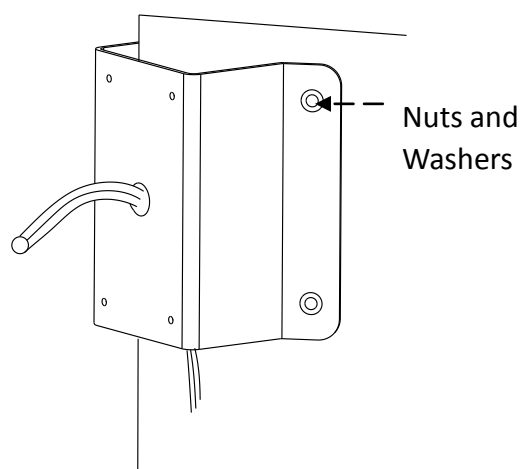

Figure 3-8 Install the Corner Adapter

Note: Make sure that the cables have enough length. For outdoor applications, please apply the sealant around the center hole for waterproof.

2. Attach the gasket then the wall mount to the corner adapter.
3. Secure the wall mount to the corner adapter with 4 hex screws and spring washers.

Note: When tightening the screw, it is better to compress the spring washer tightly first and then rotate it half-turn for water-proof without damaging the threads.

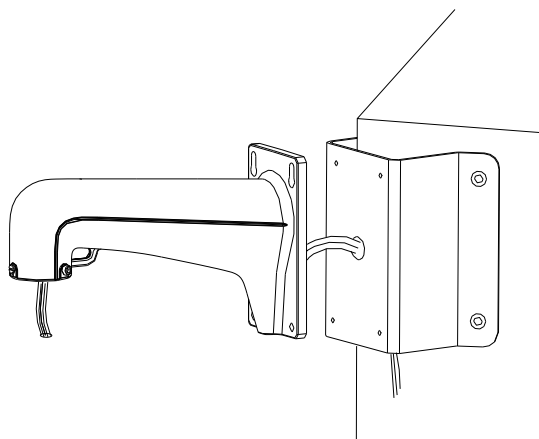

Figure 3-9 Install the Wall Mount

4. Install dome to the mount. Please refer to Section **1.2 Installation and Cabling** for installation details.

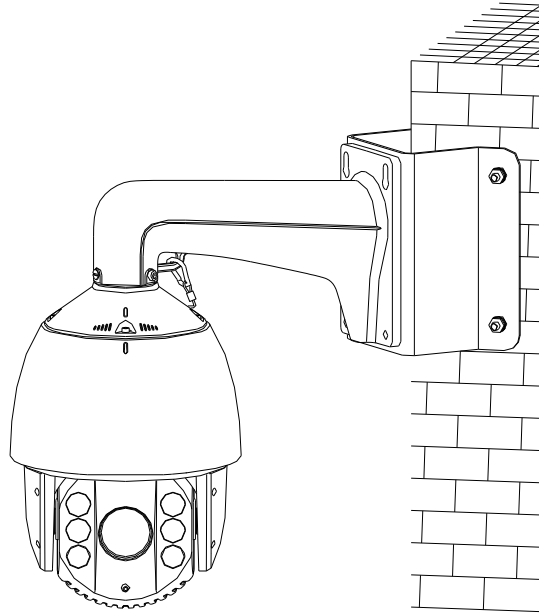

Figure 3-10 Finish the Installation

3.3 Pole Mounting Applications

3.3.1 Components

- Wall Mount

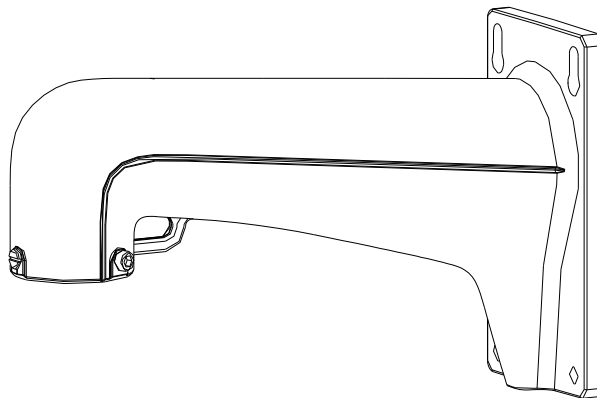

Figure 3-11 Wall Mount

- Pole Adapter

A pole adapter has to be used together with a wall mount for pole mounting applications.

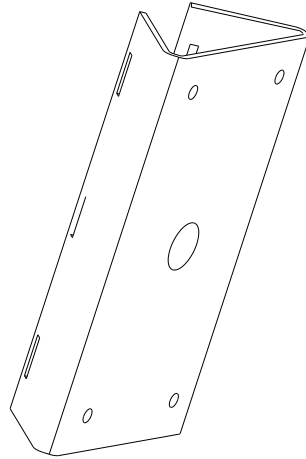

Figure 3-12 Pole Adapter

- **Pole Mounting Hoops**

Pole mounting hoop is used for pole mounting with pole adapter and wall mount. There are following dimensions selectable: $\phi 59-82\text{mm}$, $\phi 84-108\text{mm}$, $\phi 103-127\text{mm}$, $\phi 130-152\text{mm}$, $\phi 155-178\text{mm}$, $\phi 180-203\text{mm}$ and $\phi 194-216\text{mm}$. Dimensions can be customized according to your demand.

Note: The dimensions of the pole mounting hoop must match with the diameter of the pole adapter.

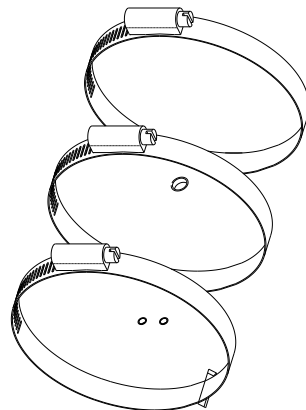

Figure 3-13 Pole Mounting Hoops

- **Mounting Accessories**

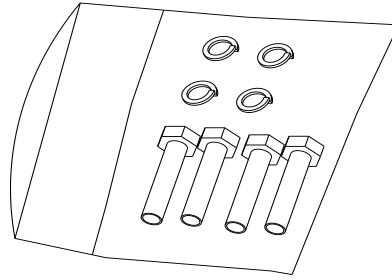

Figure 3-14 Hex Screws (M8×30) and Spring Washers

3.3.2 Pole Mounting

Steps:

1. Assemble the pole adapter.
 - (1) Loosen the three pole mounting hoops with a screwdriver.
 - (2) Insert them through the rectangle holes of the pole adapter.

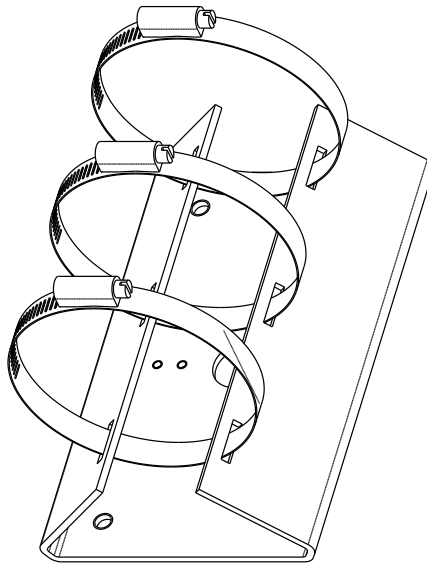

Figure 3-15 Assemble the Hoops and the Pole adapter

2. Install the pole adapter.
 - (1) Pull the control wire, video cable and power cable through the center hole.
 - (2) Secure the three pole mounting hoops to the pole, and tighten the screws of the hoops with a screwdriver.

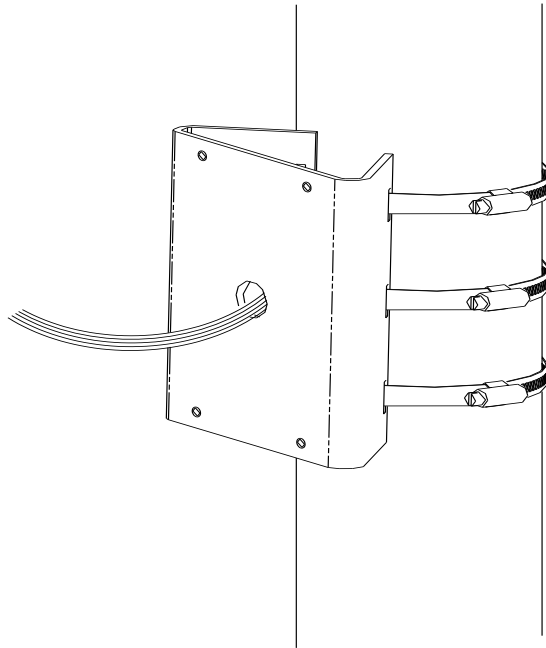

Figure 3-16 Install the Pole Adapter

Note: For outdoor applications, please adopt the water-proof measures.

3. Install the wall mount.
 - (1) Attach the gasket then wall mount to the pole adapter.
 - (2) Secure the wall mount to the pole adapter with 4 hex screws and the spring washers.

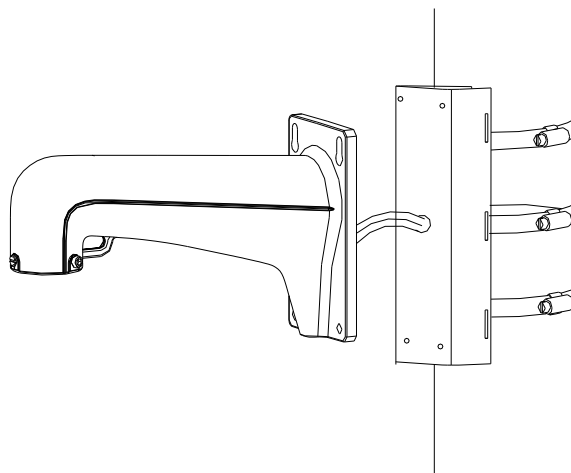

Figure 3-17 Install the Wall Mount

4. Install the speed dome to the mount. Please refer to *Section 1.1 Installation and Cabling* for installation details.

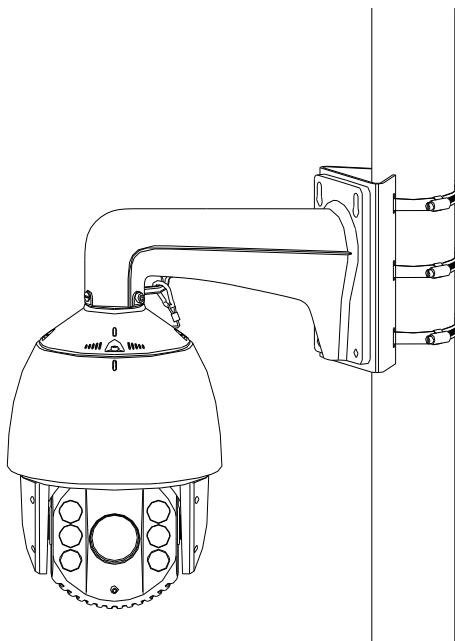

Figure 3-18 Finish the Installation

3.4 Pendant Mounting Applications

3.4.1 Components

- Pendant Mount

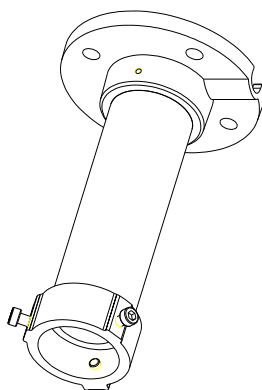

Figure 3-19 Pendant Mount

3.4.2 Pendant Mounting

Steps:

1. Install the mounting base.

Steps:

- (1) Drill four $\phi 8$ holes in the ceiling according to the screw holes of the mounting base, and then insert M8 expansion screws (not supplied) into the holes.
- (2) Pull the power cable, video cable and control wire through the cable hole of the mounting base.
- (3) Attach the mounting base to the ceiling by aligning the screw holes of the mounting base with the expansion screws on the ceiling.
- (4) Secure the mounting base by using nuts and washers to tighten the four expansion screws.

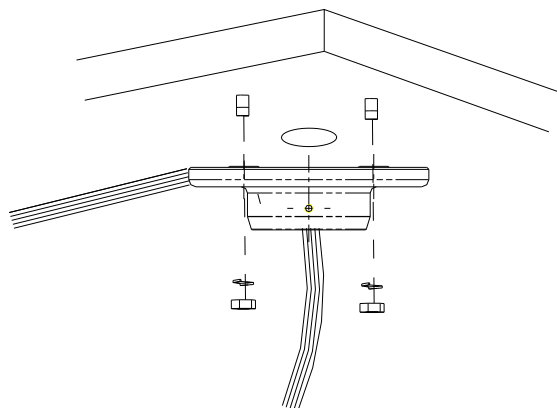

Figure 3-20 Install the Mounting Base

Note: Make sure that the cables are long enough. For outdoor applications, please apply waterproof measures between the ceiling surface and mounting base and around the cable hole. The pendant mounting application is not recommended for places where the speed dome is easily caught in the rain.

2. Install the pendant pole.

Steps:

- (1) Pull out the cables through the pendant pole and screw the pendant pole into the mounting base.
- (2) Secure the pendant pole and mounting base with the set screws.

Note: For outdoor applications, please apply the water-proof thread compound to the threads.

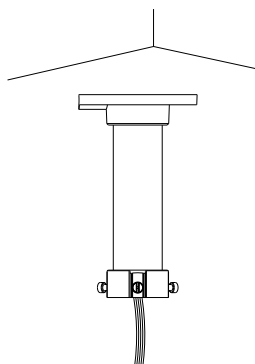

Figure 3-21 Ceiling Mount

3. Install the speed dome to the mount. Please refer to Section **1.1 Installation and Cabling** for installation details.

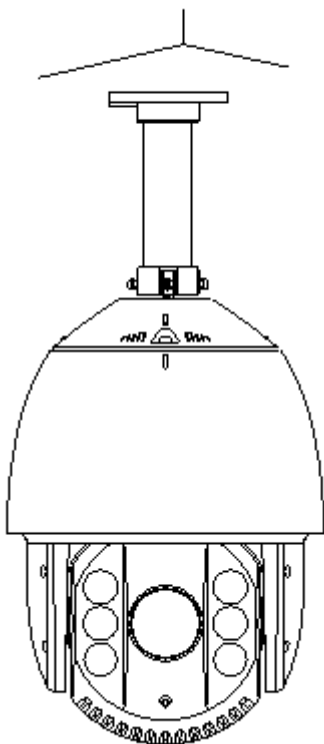

Figure 3-22 Install the Dome

Appendix

Appendix 1 Lightning & Surge Protection

This product adopts TVS plate lightning protection technology to avoid damage caused by pulse signal that is below 3000W, like instantaneous lighting stroke, surging, etc. According to the actual outdoor situation, necessary protection measures must be taken, besides ensuring the electrical safety.

- The distance between signal transmission wires and High-voltage equipment or high-voltage cable is at least 50m.
- Outdoor wiring should better be routed under eaves as much as possible.
- In the open field, wiring should be buried underground in sealed steel pipe, and the steel-pipe should be one-point grounding. Overhead routing method is forbidden.
- In strong thunderstorm area or high induction voltage areas (such as high-voltage transformer substation), high power lightning protection apparatus and lightning conductor are necessary to be added.
- The design of lightning protection and grounding of the outdoor devices and cables should be considered together with the lightning protection demand of buildings. It also must conform to the related national standards and industrial standards.
- The system should be equipotential grounded. The grounding equipment must conform to the demands of system anti-jamming and electrical safety both and it must not appear short circuit or mixed circuit with the zero conductor of strong grid. When the system is grounded alone, the resistance should be no more than 4Ω . The sectional area of the grounding cable should be no less than 25mm^2 . For grounding instructions, please refer to the Installation Manual of Speed Dome.

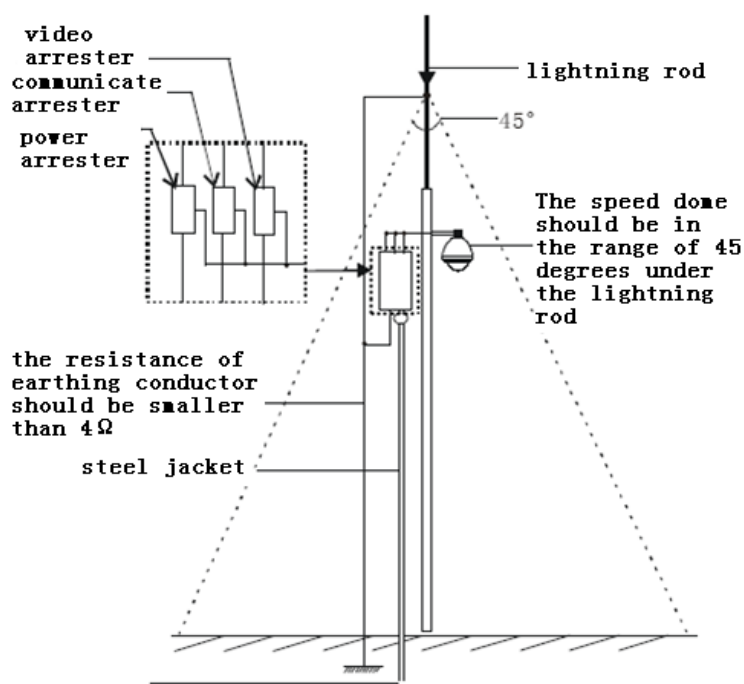

Figure A- 1 Lightning & Surge Protection

Grounding for Cement Pole/Wall Installation:

When the speed dome is installed in environment where is relatively insulating to the earth, e.g., cement pole or cement wall, then only the control center requires proper grounded locally. Refer to the following figure.

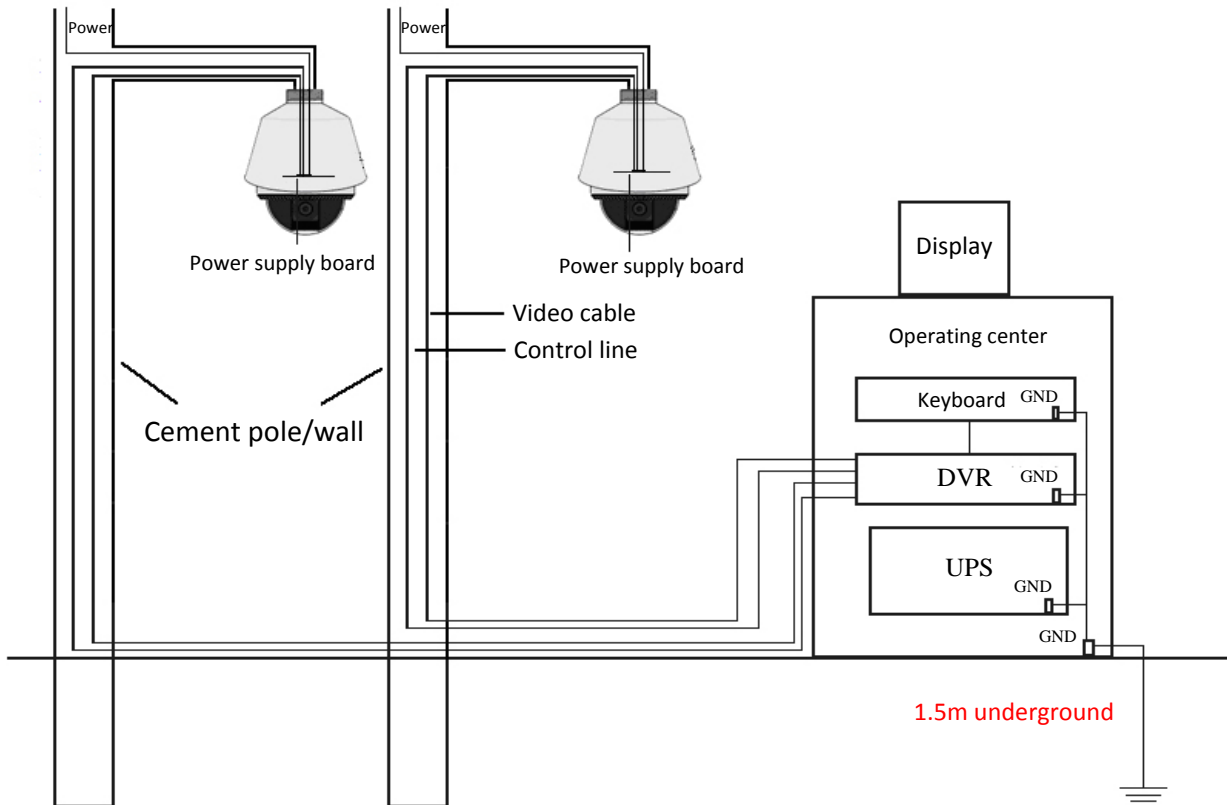

Figure A-2 Grounding in Cement Pole/Wall Installation

Notes:

- Because the signal transmission media of fiber optical speed dome and network speed dome are isolated from the control center, they must be grounded locally to protect dome against damages.
- If the dome is installed in strong thunderstorm area, it must be grounded locally to release lightning or suchlike high energy to protect dome against damages. Refer to the following figure.

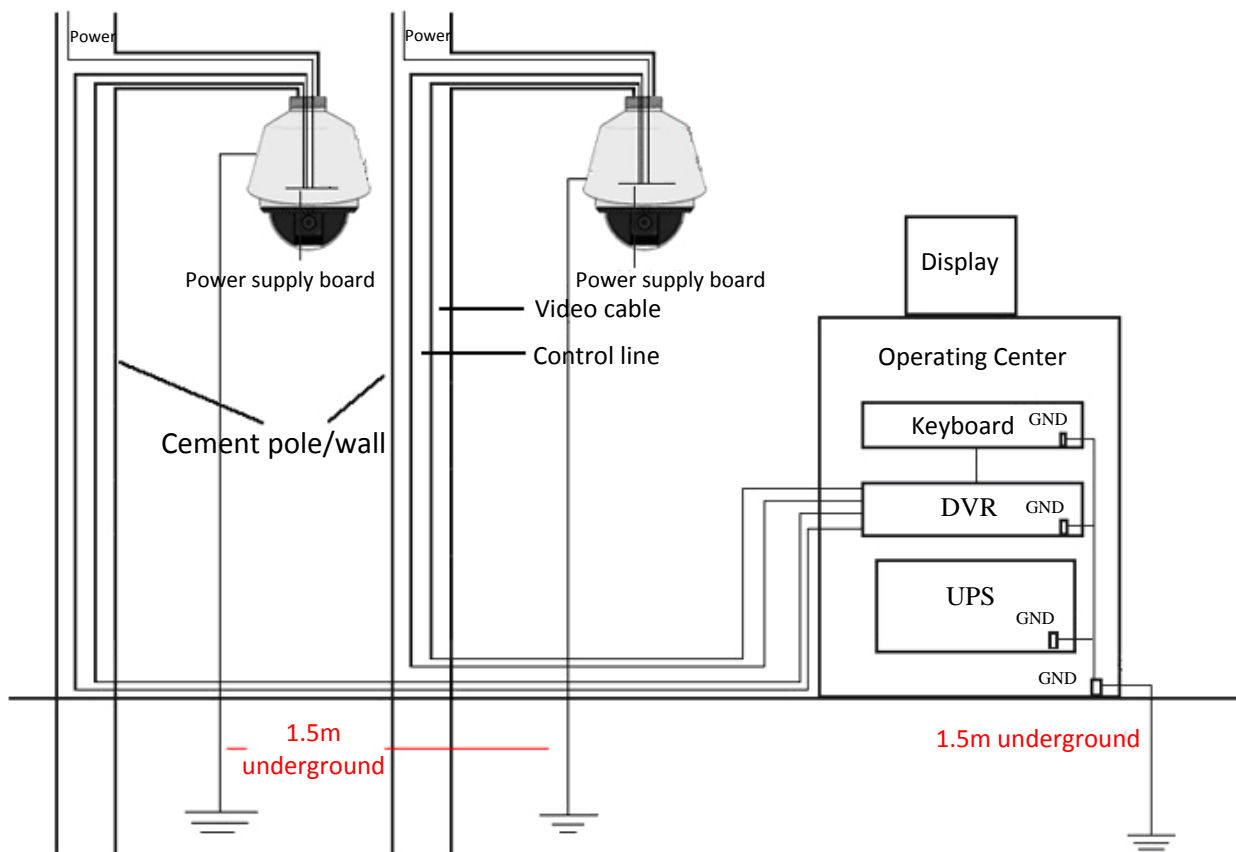

Figure A-3 Lightning-protection Grounding in Cement Pole/Wall Installation

Grounding for Metal Pole Installation:

When the speed dome is installed in environment where is conductive to the earth, e.g., metal pole, then the grounding of dome can be achieved by the properly grounded metal pole, meanwhile, the control center must be grounded locally as well. Refer to the following figure.

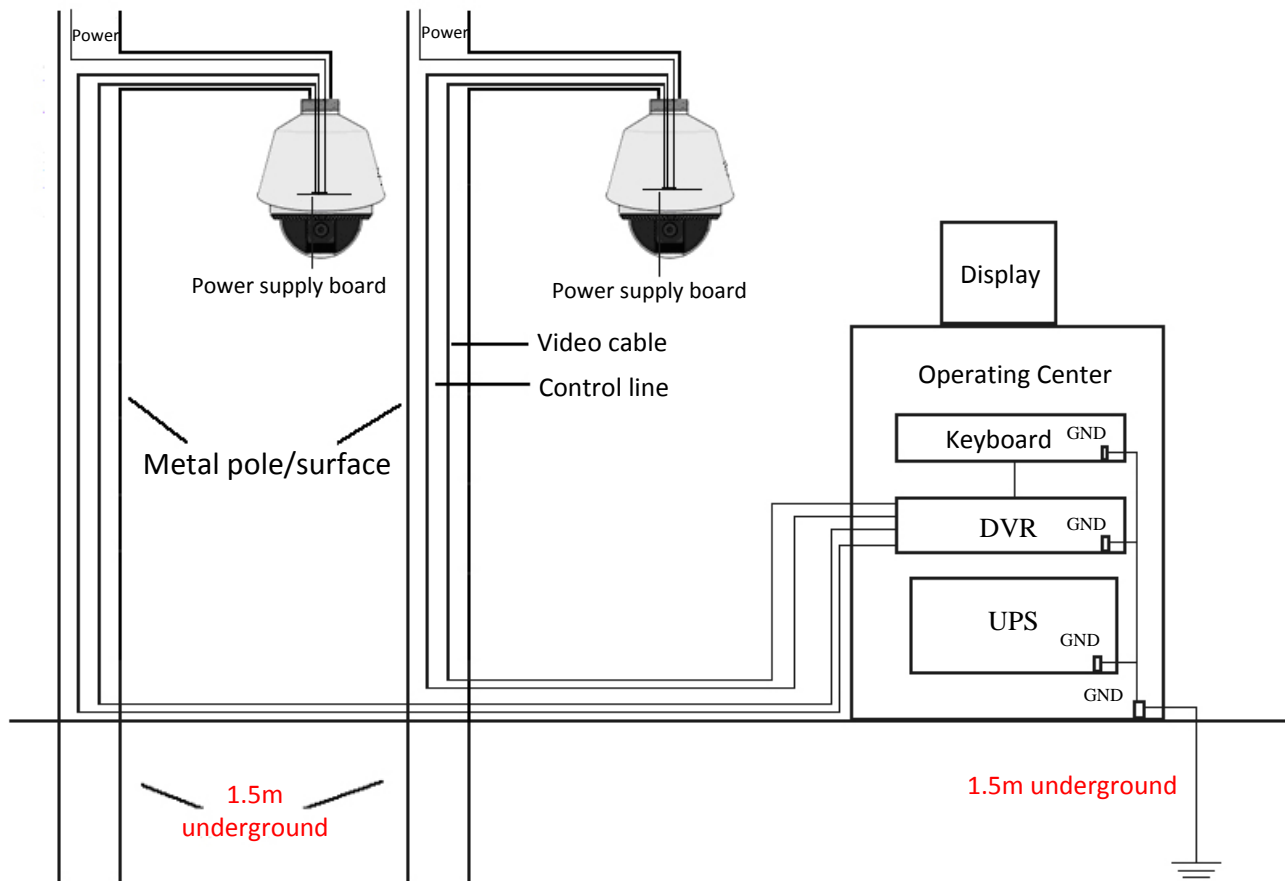

Figure A-4 Grounding in Metal Pole Installation

Note: If the fiber optics, lightning protector or other device are applied during the transmission of speed dome, such devices as well as the video cables routing through must be proper grounded.

Appendix 2 Waterproof

Notes:

- The long-arm wall mount is recommended for the outdoor application of speed dome.
- You cannot use the short-arm wall mount or pendant mount for outdoor application, because it is not water-proof.
- It is recommended to use the mount with inner threaded interface and good waterproof performance.
- If you use a mount with outer threaded interface, please adopt waterproof measures to the adapter applied between the mount and the dome.
- Do not install indoor speed dome to the outdoor environment.

L-shape Pole Mount

Make sure that the L-shape pole mount is designed with a certain inclination angle as shown in following figure. Water won't flow from the pole into the speed dome with the inclination angle.

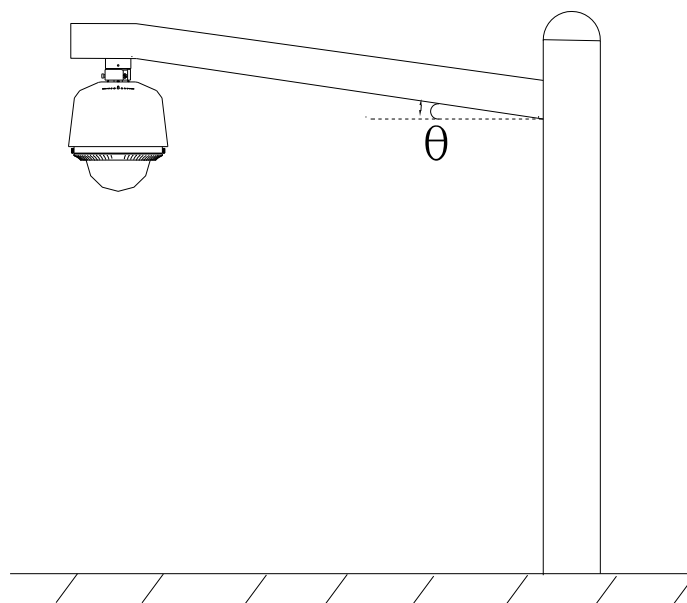

Figure A-5 Customized Mount

Long-arm Wall Mount

The long-arm wall mount is recommended for the outdoor application. The arm of wall mount is designed with a certain inclination angle to prevent incoming water, as shown in Figure A-6. During outdoor application, the long-arm wall mount can be used with the pole mount adapter or the corner mount adapter.

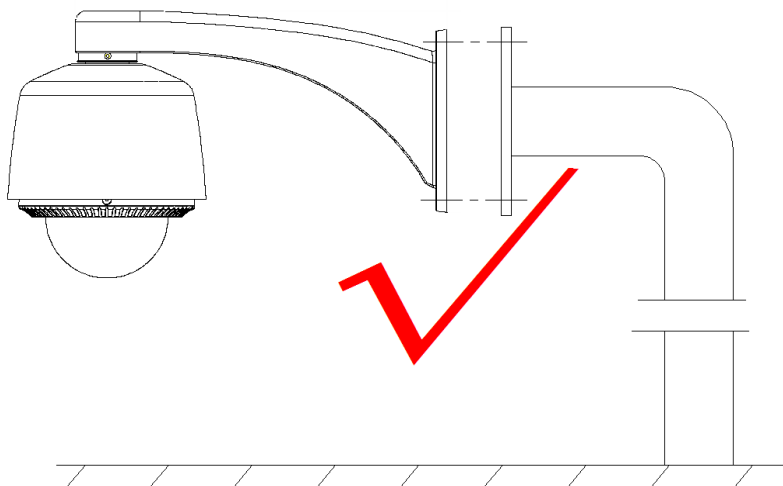

Figure A-6 Long-arm Wall Mount

Appendix 3 Bubble Maintenance

The bubble is a transparent plastic. The dust, oil and finger print, etc. will cause scratch or image blur. Please refer to the following method to clean the bubble.

- Handling dust

Use oil free soft brush or blowing dust ball to clean the dust.

- Handling oil

Steps:

1. Wipe off the water-drop or oil by soft cloth and dry the bubble.
2. Use oil free cotton cloth to wipe the bubble with alcohol or detergent.
3. Change the cloth to wipe the bubble until the bubble is clean.

Appendix 4 RS485 Bus Connection

- General Property of RS485 Bus

According to RS485 industry bus standard, RS485 is a half-duplex communication bus which has 120Ω characteristic impedance, the maximum load ability is 32 payloads (including controller device and controlled device).

- RS485 Bus Transmission Distance

When using 0.56mm (24AWG) twisted-pair line, according to different baudrate, the maximum transmission distance theory table is shown as below:

Max. Distance of RS485 Transmission	
Baudrate	Max Distance
2400BPS	1800m
4800BPS	1200m
9600BPS	800m

The transmission distance will be decreased if we use the thinner cable, or use this product under the strong electromagnetic interference situation, or there are lots of devices are added to the bus; on the contrary, the transmission distance will be increased.

- Connection Methods

RS485 industry bus standard require daisy-chain connection method between any devices, both sides have to connect a 120Ω terminal resistance (show as Diagram 1), the simplified connection method is shown as diagram 2, but the distance of “D” should not be too long.

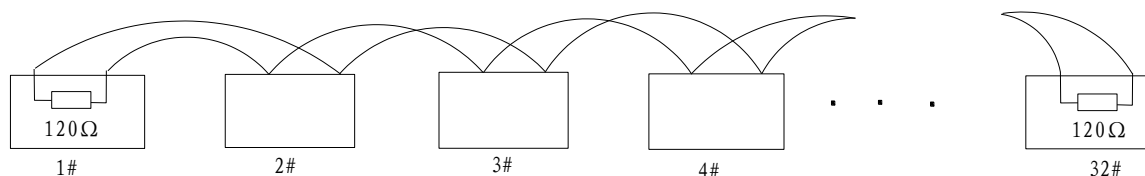

Figure A-2 RS485 Connection 1

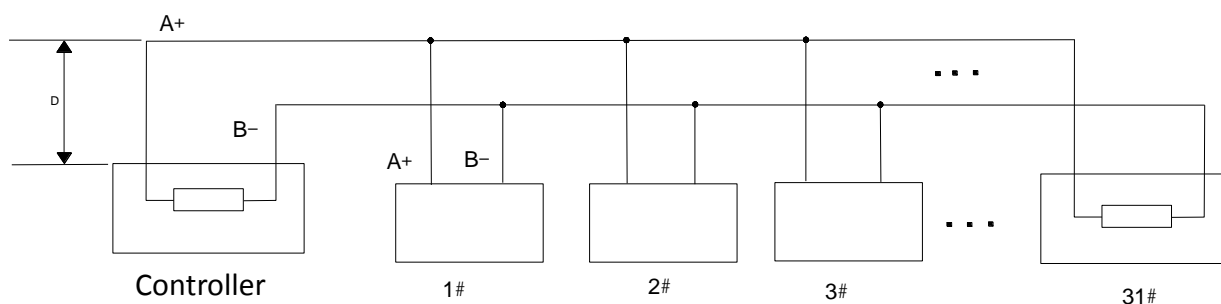

Figure A-3 RS485 Connection 2

- Problems in the Practical Application

Normally, users adopt star-shape connection method in construction, under this situation, the terminal resistors must be connected between two farthest devices (as Figure 4, 1# and 15#), but this connection method is not satisfy the requirement of the RS485 industry standard so that it will lead to some problems such as signal reflection, anti-jamming ability decline when the devices are

faraway. At this time, the dome will be uncontrollable, or self-running, etc.

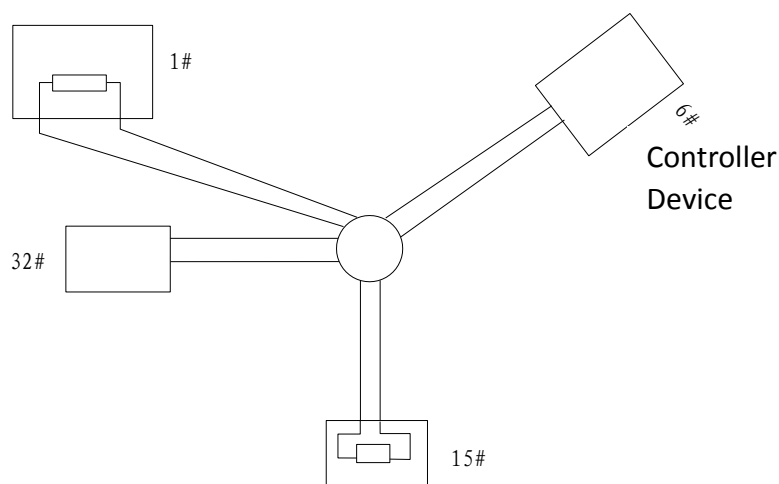

Figure A-4 Star Shape Connection

For such case, the best way is adding a RS485 distributor. This product can effectively change the star-shape connection to which satisfies the requirement of RS485 industry standard, in order to avoid those problems and improve the communication reliability. Show as figure 5.

RS485 Distributor

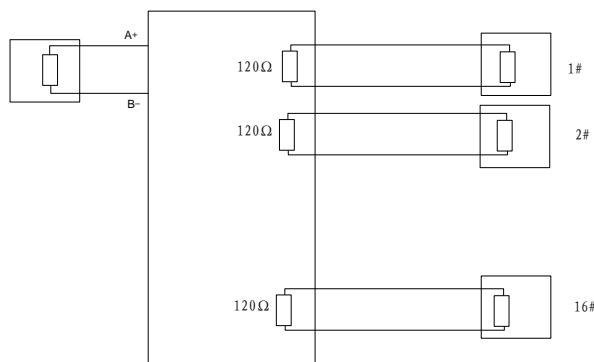

Figure A-5 RS485 Distributor

● Troubleshooting of RS485 communication

Problem	Possible Reasons	To Solve the Problem
The speed dome does the self-test action but cannot be controlled remotely.	1. The address or baudrate of the speed dome does not match with those of remote control device.	1. Adjust the address and baudrate of the remote control device to match with those of the speed dome.
	2. The wire RS485+ connects to the interface RS485- and wire RS485- connects to the interface RS485+.	2. Connect the wire RS485+ to the interface RS485+ and wire RS485- to the interface RS485-.
	3. The RS485 wire is disconnected.	3. Reconnect the RS485 wire tightly.
	4. RS485 wire is broken.	4. Change a RS485 wire.
The speed	1. The connection is loose.	1. Reconnect the RS485 wire

Problem	Possible Reasons	To Solve the Problem
dome can be controlled but not smoothly.		tightly.
	2. RS485+ or RS485-wire is broken.	2. Change a RS485 wire.
	3. The speed dome is too far away from the remote control device.	3. Add a terminal resistor.
	4. Too many speed domes are connected.	4. Add a RS485 distributor.

Appendix 5 24VAC Wire Gauge & Transmission Distance

The following table describes the recommended max. distance adopted for the certain wire gauge when the loss rate of 24VAC voltage is less than 10%. For the AC driven device, the maximum voltage loss rate is 10% allowable. For example, for a device with the rating power of 80VA which is installed at a distance of 35 feet (10m) away from the transformer, then 0.8000mm is required as the minimum wire gauge.

Distance (feet) \ Wire Gauge (mm) \ Power (va)	0.8000	1.000	1.250	2.000
10	283 (86)	451 (137)	716 (218)	1811 (551)
20	141 (42)	225 (68)	358 (109)	905 (275)
30	94 (28)	150 (45)	238 (72)	603 (183)
40	70 (21)	112 (34)	179 (54)	452 (137)
50	56 (17)	90 (27)	143 (43)	362 (110)
60	47 (14)	75 (22)	119 (36)	301 (91)
70	40 (12)	64 (19)	102 (31)	258 (78)
80	35 (10)	56 (17)	89 (27)	226 (68)
90	31 (9)	50 (15)	79 (24)	201 (61)
100	28 (8)	45 (13)	71 (21)	181 (55)
110	25 (7)	41 (12)	65 (19)	164 (49)
120	23 (7)	37 (11)	59 (17)	150 (45)
130	21 (6)	34 (10)	55 (16)	139 (42)
140	20 (6)	32 (9)	51 (15)	129 (39)
150	18 (5)	30 (9)	47 (14)	120 (36)
160	17 (5)	28 (8)	44 (13)	113 (34)
170	16 (4)	26 (7)	42 (12)	106 (32)
180	15 (4)	25 (7)	39 (11)	100 (30)
190	14 (4)	23 (7)	37 (11)	95 (28)
200	14 (4)	22 (6)	35 (10)	90 (27)

Appendix 6 Wire Gauge Standards

Bare Wire Gauge(mm)	American Wire Gauge AWG	British Wire Gauge SWG	Cross-sectional Area of Bare Wire(mm ²)
0.750	21		0.4417
0.800	20	21	0.5027
0.900	19	20	0.6362
1.000	18	19	0.7854
1.250	16	18	1.2266
1.500	15	17	1.7663
2.000	12	14	3.1420
2.500			4.9080
3.000			7.0683

