

F & SC Serial Access Control Station

Installation instruction

Version: 1.1.1

Date: June 2010

About This Manual

This document describes the F & SC Serial Access Control Station installation guide and wiring instruction.

About this Guide

- The F&SC Access Control Station User guide is designed to provide information to install the F& SC serial Access Control Station, for operation and configuration, please refer to the corresponding user's manual.
- Not all function these guides introduce available in combination, all is option.
- About your machine function, please consult our company technical personnel or the sales personnel.

Information in this document is subject to change without notice.

Contents

1 Before Installing	1
1.1 Notice about installing	1
2 System Configuration	4
2.1 The illustration of system construction	4
2.2 The sketch map of communication	5
3. Installation	6
3.1 Fixing mounting plate	6
3.2 Connect with peripheral equipment	7
3.2.1 Door Sensor	9
3.2.2 Release Button	9
3.2.3 Alarm	9
3.2.4 Conntion with lock	10
3.2.5 Ethernet connection	16
3.2.6 Connection with RS232	18
3.2.7 Connection with RS485	18
3.2.8 Wiegand output	20
3.2.9 Power connection	21
3.2.10 Connect with external Weigend reader	21
3.3 Fixing Access Control Station	22
4. Fastening Access Control Station	23
5. Others	24
5.1 Reset	24
5.2 Anti-dismantle button	24
5.3 Cable doorbell	25
SC Series rechargeable battery specifications	26

1 Before Installing

1.1 Notice about installing

Access Control Station is a mass-produced product. It strictly tested comply with the standard of China, U.S.A, and EU. This file contains important information. It is better for you to read it carefully prior to use. If you ignore it, the incorrect installation may cause the unit damage. Although we could do our best to offer you service, the neglect to the file could cause unwanted cost for you.

1. Before installation, please make sure the power is cut off, because it is very dangerous if the power is on. The short circuit of power cable may cause the core parts damage.
2. All exposed part of connection wire end cannot be exceeded 5mm to prevent the bared wire accidental connection which leads to machine break down. And also suggest using different color cable to connect.
3. In the place where the static is strong or in winter, please connect the grounding firstly, in order to prevent the instant mass static damage the machine.
4. Connect power supply with device in the last for the wiring connection. If you find any unusual thing occur, please firstly cut off the power, then go to examine. Keep in mind: wiring operation under power on will lead to machine sudden damage; we are not liable for damages and trouble due to such operation.

5. The height to mount device is about 1.4-1.5 meter
6. After installation, please take off protection film on the fingerprint sensor to get best recognize result.
7. After installation finish, when go to test the exit-door button, please keep a personal in the outside, because sometimes the accidental issue can bring on you are not able to go outside.
8. Our equipment offer an automatically function, please after the installing finish. Run the auto-test function to confirm the installation finish.
9. We recommend using above the 12V/3A direct-current supply for ZK software's access control device, electricity lock better to powered by 12VDC, and no more than 1.5 A electric current. At this time, the electric current of supply should be above 1A than lock power. If the parameter of lock power surpasses this scope, please connect technical personnel. If the power had not met above requests, it possibly causes to be unable normally to drive the electricity lock, even damage the device.
10. Before device to be connected please read and always follow "Quick connect Guide" closely. Because the wrong wiring will cause the core block and sensor to burn out, insult in device to break down, at this cause ZK Software is not liable for any damages and trouble.
11. If the space between power adapters and device is too long, please do not use the twisted-pair or other type ferrules for the power wire. When the power wire is choused, you should consider attenuation of voltage, which has passed long distance transfer.
12. Please use specialized RS485 cable and the RS232/485 converter with power to hookup the network, the bus structure apply to connect

with each device. When a long cable is used to transfer signal, it is need to connect a matching resistance to receiver, and its value is 120Ω .

13. Other more details items; please see also the user manual, the operating instructions and the appendix and so on.

2 System Configuration

2.1 The illustration of system construction

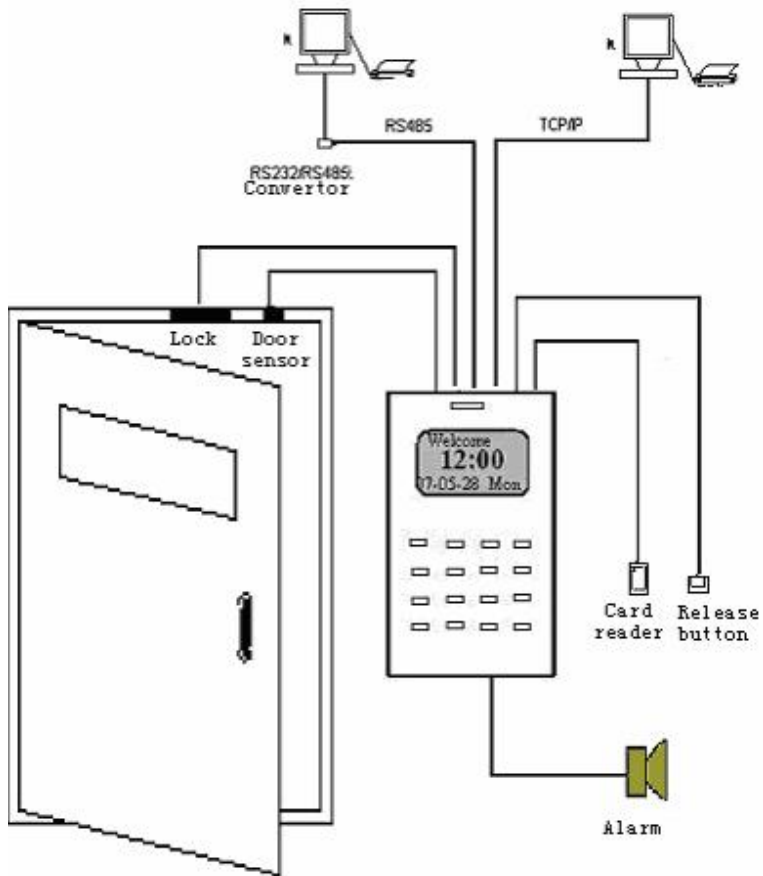

2.2 The sketch map of communication

Access Control Station directly connects with PC through RS232 or TCP/IP



Access Control Station connects with PC through RS485 network

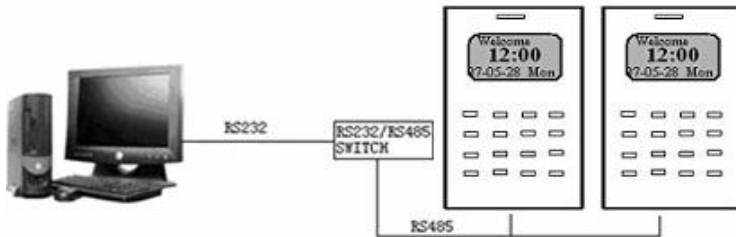

3 Access Control Station connects with PC through TCP/IP network.

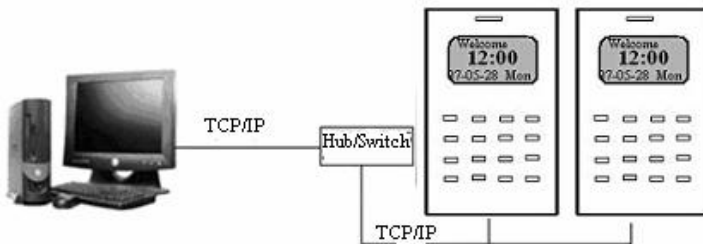

3.Installation

3.1 Fixing mounting plate

- ① Take out a Access Control Station, dismantle the screw between machine body and mounting plate until it is out, see figure (1).
- ② Carefully take up the bottom of mounting plate, see figure (2), push it up, see figure (3), then take away the mounting plate.
- ③ Determine the position of mounting plate on the wall. The Access Control Station should be mounted on the external wall of the door approximately 1400mm from the ground to the unit bottom. After the position is determined, you could drill a hole (18mm*20mm) for cable out, see below figure shadowed part.
- ④ Make the hole of mounting plate meet the drilled hole on the wall, Use the screw to fix it on the wall, (for the details please see following figure)
- ⑤ after installation, please make sure the mounting plate is reliable, fasten, not loosed.

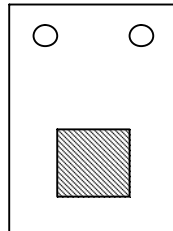
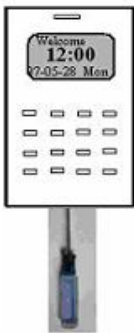

3.2 Connect with peripheral equipment

Caution: Do not to connect peripheral equipment before the power of the device is cut down, otherwise it is possible to damage the device badly.

Please follow instruction to connect peripheral equipment

- ① Door sensor connection (sensor, GND)
- ② Exit-button connection (Button GND)
- ③ Alarm connection (Alarm+, Alarm-)
- ④ Door lock connection (NC, COM, NO)
- ⑤ Ethernet connection (RJ45-1, RJ45-2, RJ45-3,RJ45-4)
- ⑥ RS232 connection (232RX, 232TX, GND)
- ⑦ RS485 connection (485A,485B)
- ⑧ Wiegand output connection (WD0,WD1,GND)
- ⑨ Cable Bell (Bell+, Bell-)
- ⑩ Power connection (GND, +12V)

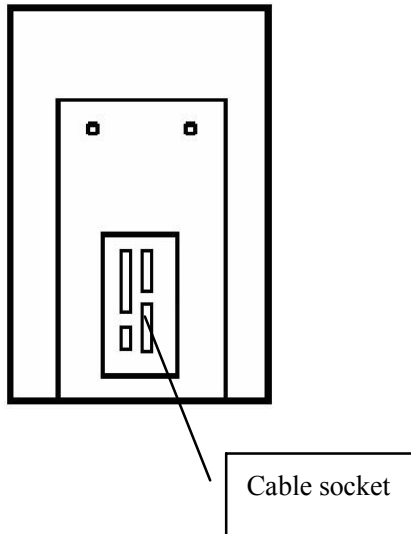

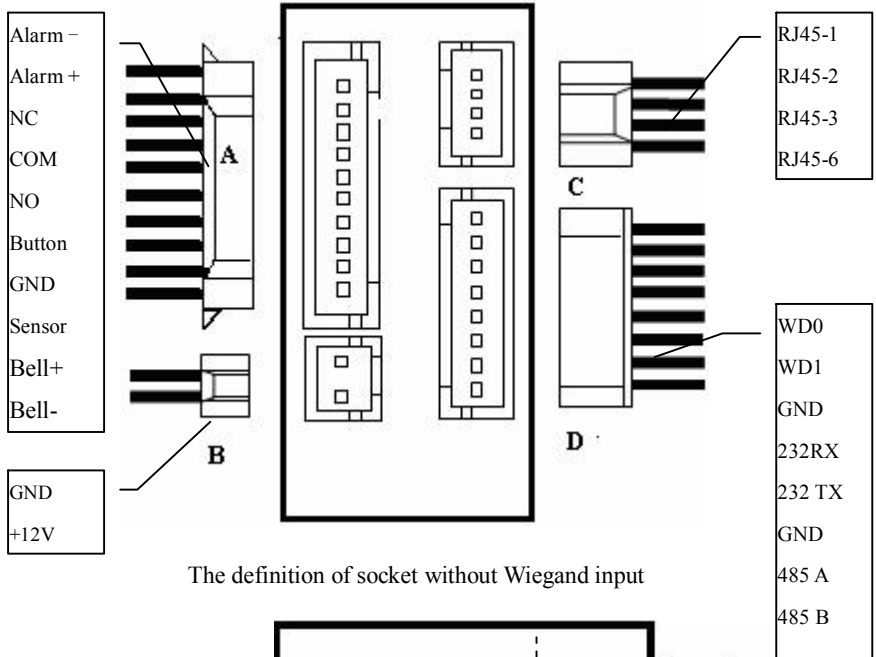

The definition of socket without Wiegand input

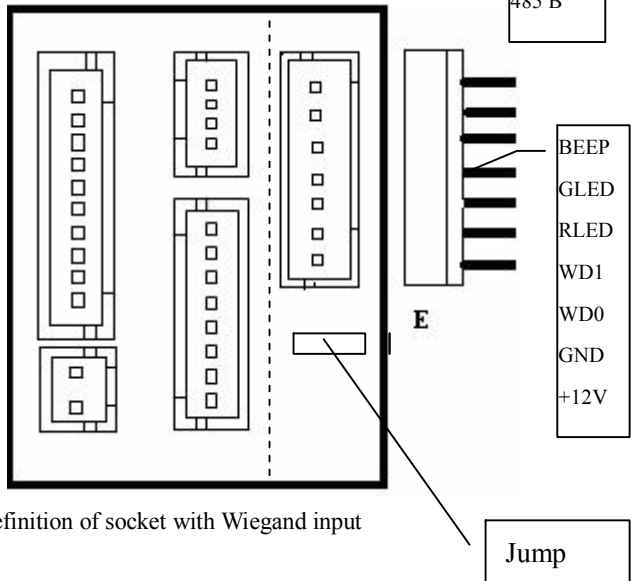

The definition of socket with Wiegand input

3.2.1 Door Sensor

The door sensor is used to detect the door open-close status, Access Control Station can monitor if the door has been unauthorized open through the door sensor, at this time it can output a alarm signal, moreover, Access Control Station can trigger prompt warning if after surpassing a timed period, the door still open.

3.2.2 Release Button

The exit-button is installed for in-door operation. When the switch of the button is close, the door will open. The distance is approximately 1400mm from ground to exit-button bottom. Make sure that the exit-button position is to align correct, upright and the connection is accurate and reliable. (Unused exposed end of cable should be cut off, and use insulating tape to wrap it.) Pay attention to electromagnetic disturbance. (For example: The light switch, the computer and so on)

3.2.3 Alarm

Access Control Station alarm output is a switch signal, it is able to connect with simple alarm by serial circuit, it also apply to top grade alarm and monitor system as a trigger signal(this machine alarm function only support 12 VDC Warner)

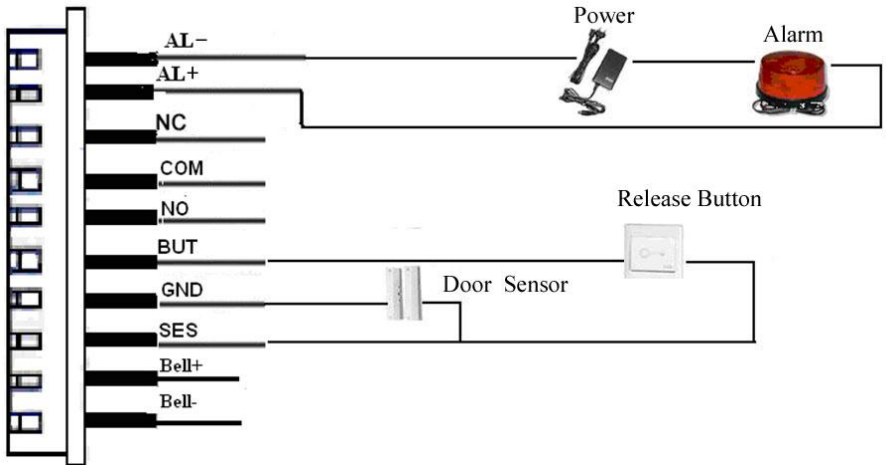

3.2.4 Conntion with lock

The way of installing door lock depends on the type of lock and local condition. Internal resistor, which comes from long distance transfer, should be taken into consideration when selecting the cable of electric power. The door lock should be installed reliable and stable. Ensure the wiring is correct. For the strike lock and electromagnetic lock, you should pay attention to positive and negative terminal connection. The unused bare end of wire should be cut off and use insulating tape to wrap it. The delay time of strike lock is adjustable according to different conditions.

Normally close (NC), under normal state the equipment keeps up closed, if force the equipment open, the circuit cut off, brings out the state change.

Normally Open (NO), under normally state the circuit is cut off, if force the equipment open, the circuit will be closed, and produce a state

change.

Power Ground (GND), Current loop ground

Input terminal of door sensor (Sensor, GND) the input port of door sensor accepts the signal which come from normally closed contact to detect the door opening and closing state, when the door is in closed, the contact keep in closed state, if the door is opened by someone , the circuit break, thus bring out state change. If unauthorized user opens this door or opening time is too long, the controller will send alarm

Input terminal of release door button (Button, GND) The input port of release door button accepts the signal which come from normally opened contact to indicate that somebody want to go out, the input equipment such as “ action detector”, “ press sensitivity floor board” or exit-door button all serve as source to send signal, if nobody send out request to want to go out, the input keep disconnection , if somebody want to go out, they trigger release door button, the circuit is closed. Produce state change, the controller responded to the request, unlock and permit door serve as passage mode.

Note: 1) the process of performance to unlock door is control by relay, when you install door lock, there are two thing you must think about, -- safety and security , in other words, do you want which result that is if lose control of this door, the door is still in safety—“lost control but safety” or if lose control of this door, the door still is security--- “ lost control but security”

2) When the Access Control System connected with Electric lock, to prevent the self-inductance EMF to affect the access control system, you need to parallel one FR107 diode (do not reverse the polarity) .

Please use the equipped diode in the package.

“Lost control but safety” is that the power supply cut off (maybe the power supply is cut or the controller lose control of itself, the door will be open automatically, and permit everybody freely to pass in and out, the door is not ability to be closed until the system power on, these type of doors are installed in the protective area which ensure everybody is able to pass in and out. One representative application of “lost control but safety” is to use electromagnetism lock, under normal power supply, the door is controlled by the controller, once the power supply break off, the electromagnetism lock will lose magnetism and does not take effect, the door become a passage mode

“Lost control but security” is that the power supply cut off, the door will be locked automatically, do not permit external personal to come in, but permit internal personal go out, the door is not to be unlocked until the system power supply is in gear. Make sure that the door of “lost control but security” will be installed in the area, which needs to be protected through fair and foul. One representative application of “lost control but security” is to use electrical lock, if the power supply break off, the external personal is not able to open the door, but the internal person can open the by manual operation.

In the following three cases, we recommend that fingerprint machine and lock be powered separately.

- 1) The working voltage of the lock is DC12V, but the current difference of the fingerprint machine and the lock doesn't exceed 1A.
- 2) The lock voltage is not DC12V.

3) The distance between lock and fingerprint machine is too far.

1、 NC lock connection (Access Control Station and lock power by one adapter together , Jump 2,3 pin closed) .

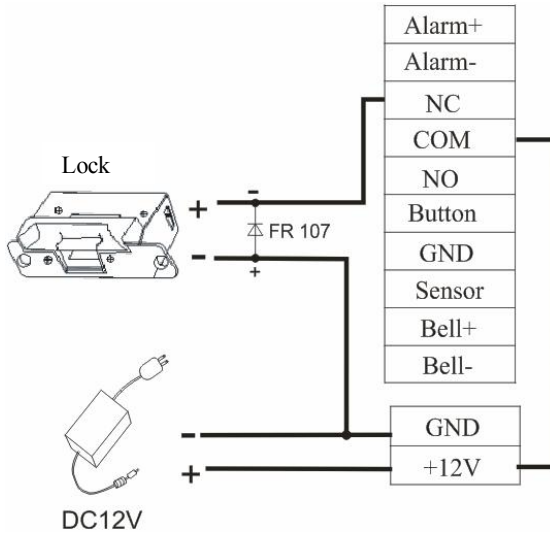

2、 NO lock connection (Access control Station and lock powered by one adapter together , Jump 2.3 pin closed) .

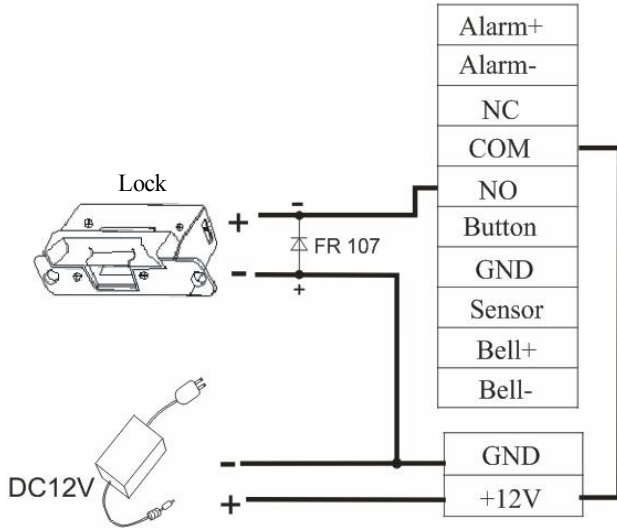

3、 the output relay signal by Access control station, NC lock connection (Access Control Station and lock powered by independent adapters jump 1,2 closed) .

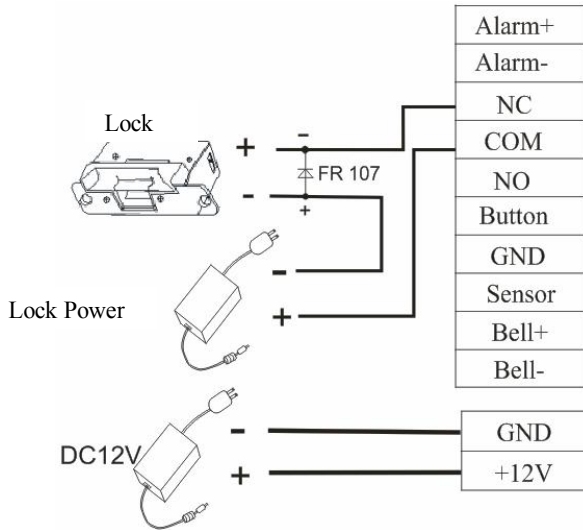

4、 the output relay signal by Access control station, NO lock connection
 (Access Control station and lock powered by independent adapter

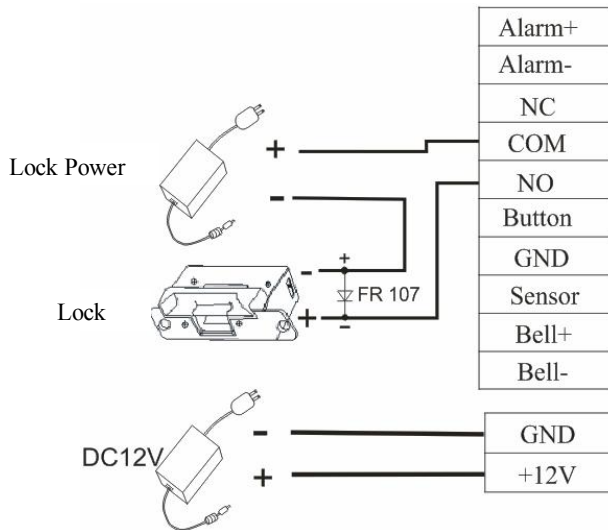

3.2.5 Ethernet connection

- 1) Access Control Station connects with PC through cross cable



- 2) Access Control Station connects with PC through network and HUB to create a local network

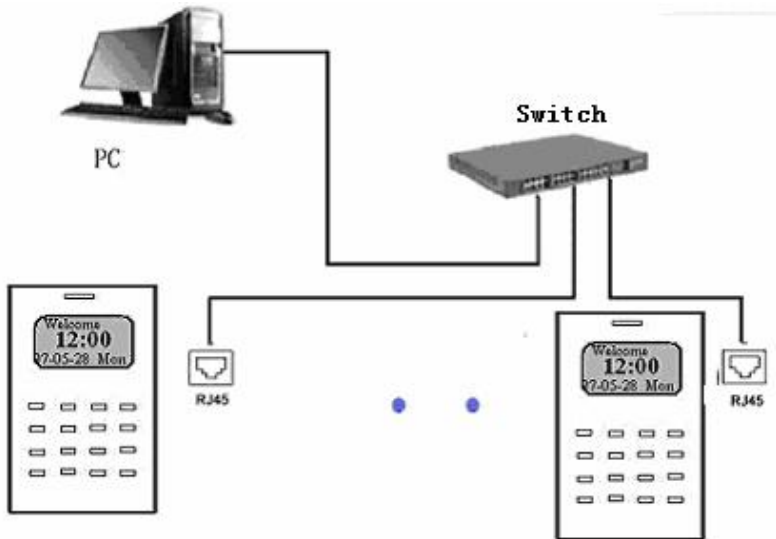

3) RJ45 plug wiring diagrams for Ethernet

a) RJ45 plug standard

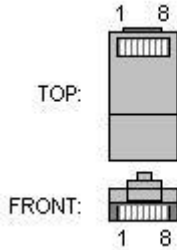

b) Ethernet 10/100Base—T Crossover Cable

mostly apply to HUB and Switch, or directly connect two Ethernet terminals(not through HUB), fully support 10Base-T and 100Base-TX.

<i>Plug1</i>	<i>Pin</i>		<i>Pin</i>	<i>Plug 2</i>
TX+	1	<—>	3	RX+
TX-	2	<—>	6	RX-
RX+	3	<—>	1	TX+
RX-	6	<—>	2	TX-

c) Ethernet 10/100Base-T Straight Thru Cable

Support 10Base-T and 100Base-TX, apply to connect with network card and HUB (or network outlet), sometime it is called (whips)”

<i>Wiring standard</i>	<i>Pin</i>	<i>Color</i>	<i>Pin</i>	<i>Wiring standard</i>
TX+	1	<— white orange —>	1	TX+
TX-	2	<— Orange —>	2	TX-
RX+	3	<— white green —>	3	RX+
	4	<— Blue —>	4	
	5	<— Blue white —>	5	
RX-	6	<— Green —>	6	RX-
	7	<— White brown —>	7	
	8	<— Brown —>	8	

3.2.6 Connection with RS232

The definition of PC connection with Access Control Station

PC Serial Port	Access Control Station serial port
Pin2-Rxd	Pin5-Txd
Pin3-Txd	Pin4-Txd
Pin5-Gnd	Pin6-Gnd

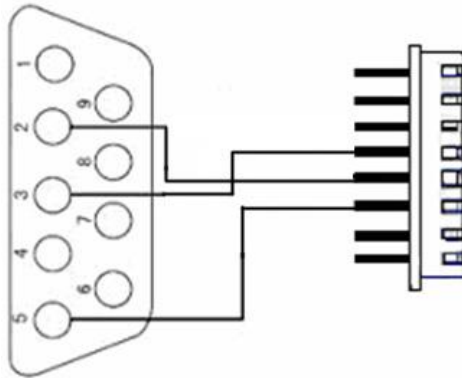

3.2.7 Connection with RS485

The definition of terminal connection

Terminal	Function
Pin1-485A	RS-485 communication +
Pin2-485B	RS-485 communication -

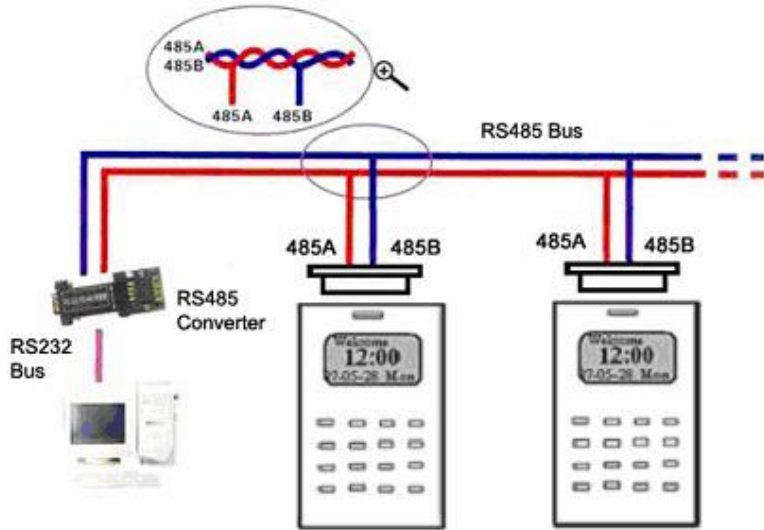

3.2.8 Wiegand output

Access Control Station provide standard Wiegand 26 output, which can be connected to most of access controllers, like the way of connecting with a ID reader or password keyboard. The distance from the controller to device cannot be more than 15 meter (if the signal must be transferred much further or there is a strong interference around, please adopt a Wiegand signal amplifier)

Note: no matter the device is powered by access controller or not, the ground ports of them have to be properly together to ensure the Wiegand transfer reliable

Terminal	Function
Pin1-WD0	Output Wiegand data 0 signal
Pin2-WD1	Output Wiegand data 1 signal
Pin3-GND	Ground

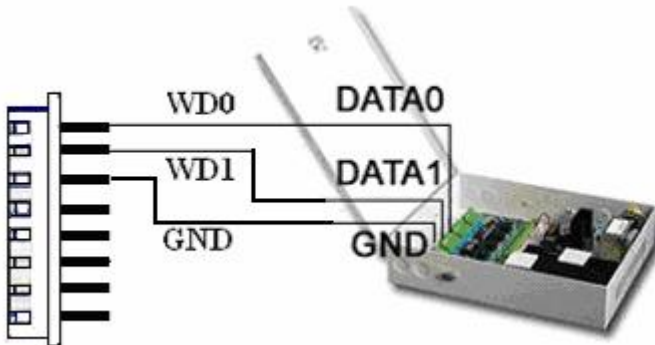

3.2.9 Power connection

This device is powered by 12VDC. Its current is approximately 50mA in the ready work status and 400mA in the work status. The power is conducted along with the terminal; you can use the 12V-4A-supply adapter that is provided along with the device. The detail about connection is as follow.

Terminal	Function
Pin1- GND	Power negative
Pin2- PWR	Power positive

The following figure is an example, which takes a provided power adapter to connect

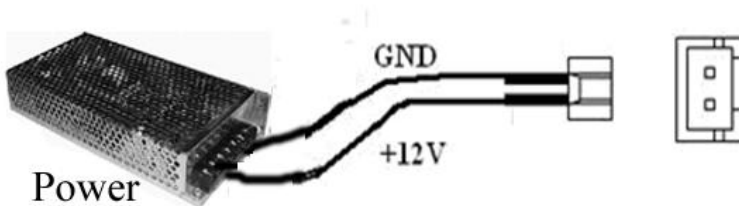

3.2.10 Connect with external Weigend reader

Access control device with the Weigand input function is able to connect with card reader, which is located in outdoor or indoor, control the door by the controller together, the cable which between access controller and external card reader is no more than 90 meter.

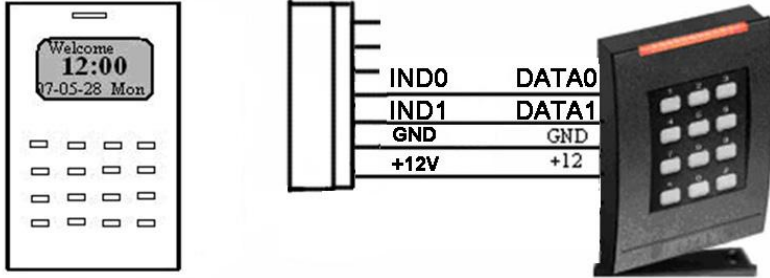

3.3 Fixing Access Control Station

- ① Confirm all connection plugs correctly.
- ② Align back iron-plate of Access Control Station body to mounting plate properly, and push it up, see figure1, then push device backward, see figure 2.
- ③ Turn and tie up the screw bottom.

After finishing installation, make ensure the body of device is fixed tightly.

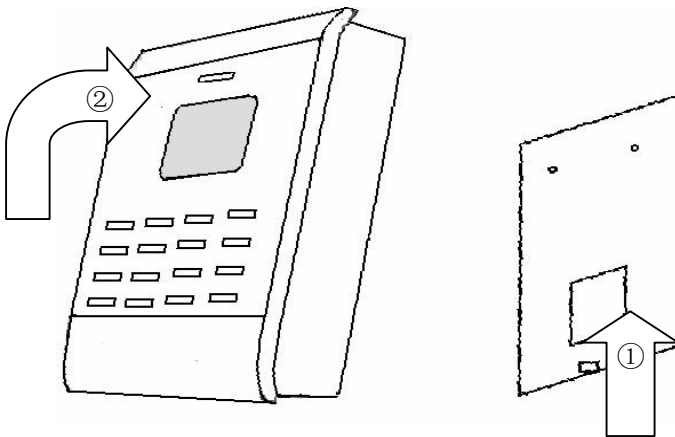

4. Fastening Access Control Station

After all system installation finished, make a test and examine prior to power on, inspect whether the lock driver is OK or not, for more details, please see “User Guide” and “Software Manual”

- ①the green LED begins to glitter after power up.
- ②enter menu-〉 Option-〉 Auto-test.
- ③enter menu-〉 User manage-〉 User Enroll-〉 Fingerprint Enroll, Enroll a fingerprint, and use the fingerprint to test access control system and door lock..
- ④if there is no any problem. Please delete this enrolled fingerprint.

5. Others

5.1 Reset

Due to operation error or other accident, which leads the machine not to work, you can restart machine through reset key.

- ①take a small tool which diameter is no more than 2mm.
- ②find reset mark of “res” on the left small hole on the bottom of device, see following figure.
- ③Use the tool plug into the hole refer to the picture on right, then plug out. The machine is able to restart.

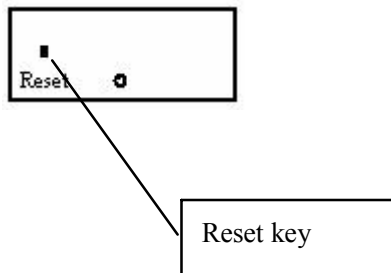

5.2 Anti-dismantle button

Anti-dismantle button is on middle of device, whose function is realized by back-cover pressing the anti-dismantle button. When the device is being dismantled, it will send an alarm signal through the terminal.

5.3 Cable doorbell

There is a key which is remark as icon (🔔) on the keypad , this key is used for doorbell.

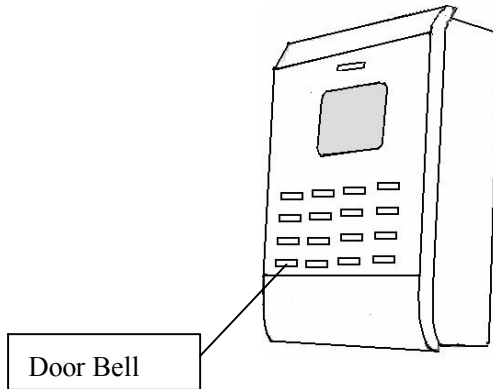

Put the doorbell in the proper place, press the doorbell key on the device, please see circle marked, after the doorbell receive a signal, it will ring.

Note: Because the terminal and key our provided is used for cable doorbell, must join the power into the electric round.

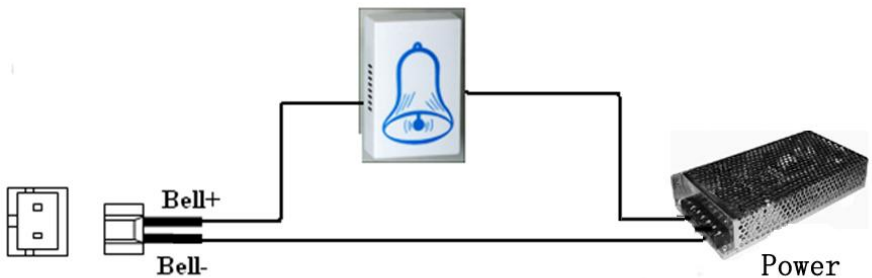

SC Series rechargeable battery specifications

specifications

- Model: MS621F
- Nominal voltage (V): 3
- Charging voltage (standard charge voltage): 2.8V-3.3V (3.1V)
- Nominal capacity (mAh): 5.5
- Internal resistance (Ω): 80
- Standard charge and discharge current (mA): 0.025
- The largest discharge current (continuous) (mA): 0.25
- Life cycle (times): 100% charge and discharge: 200; 20% charge and discharge: 1000
- Size (mm): diameter: 6.8; Height: 2.1
- Weight (g): 0.23

Features

- Discharge capacity
- 3.3 V-2.0V with the high voltage at the same time, you will receive a large discharge capacity. Charge and discharge cycles long► life
- Under the 3.3 V-2.0V the charge and discharge conditions (discharge depth of 100%), can achieve more than 200 rounds of the charge and discharge.
- Excellence in the discharge
- A discharge to 0.0 V so far, can also show a stable discharge capacity.

- UL (Underwriters Laboratories Inc) specifications (UL File No.MH 15628)

Application

- Mobile, office equipment, and other electronic equipment, sever as the standby power for clock functions of kinds of memory.
- discharge ⇄ characteristics

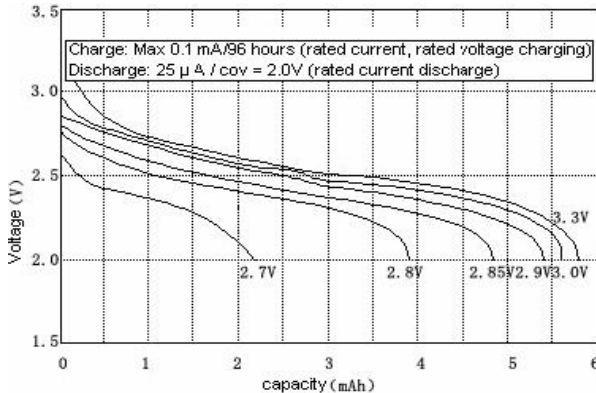

Charge: Max 0.1 mA/96 hours
(rated current, rated voltage
charging)
Discharge: 25 μ A / cov = 2.0V
(rated current discharge)

Discharge characteristics

Proposed rated voltage. Because of the charge current restrictions, the need to connect to the current limit resistance

Nominal capacity: 3.3 V-2.0V, / FS products in the discharge capacity of 3.1 V-2.0V within the typical scope

Internal resistance by the exchange value of Alternating Current

The largest discharge current: the available capacity of about 50 percent , the current capacity of

Maintain the minimum capacity of 50 percent.

The number of repeated charge 100% and 20% of the nominal capacity as the standard.