

**1. Cautions**

- ⚠ Please notice the following cautions. Mis-operation may lead to personal injury or equipment failure:
- 1) Do not energize the system before installation is complete. Never carry out installation activities when the system is energized.
  - 2) All peripheral devices must be grounded.
  - 3) It is recommended that all wires run through casing pipes which may be PVC or galvanized ones.
  - 4) It is strongly recommended that the length of exposed part of any connection cable should not be longer than 4 mm. Professional clamping tools may be used to avoid unintentional contact of exposed wires to avoid short-circuit or communication failure.
  - 5) It's recommended that card readers and buttons installed at height of 1.4m-1.5m above ground
  - 6) It is recommended to use the power supply in case for control panel, and external power supply for each lock.

**2. Equipment Installation**

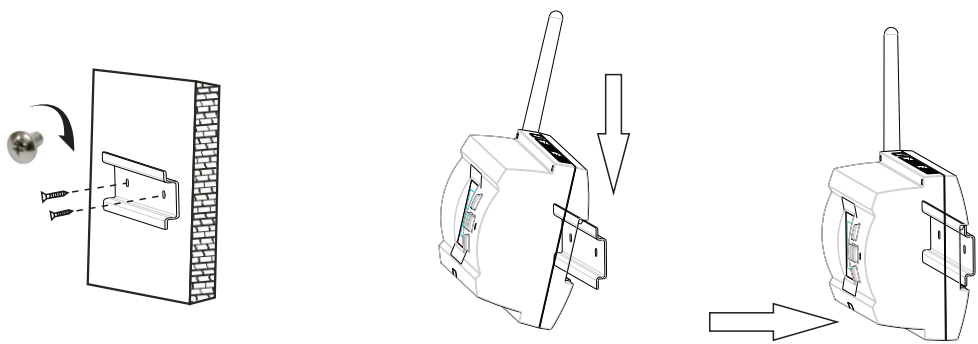

- 1) Select two of the elliptical holes on the rear iron cover. Drill two holes on the surface for fixing (Which may be on a distribution cabinet, ceiling or other weatherproof position).
- 2) Hang the equipment on the upper edge of the rear iron cover, and then press the equipment down.
- 3) Push the equipment backward to hang the entire equipment onto the rear cover.

**3. Lock Connection**

- 1) The access controller provides lock control output. For a lock which should be open when being energized and be closed when being de-energized, the "COM" and "NO" terminals should be used. For a lock which should be open when being de-energized and be closed when being energized, the "COM" and "NC" terminals should be used.
  - 2) If the electrical lock is connected to the access control system, you need to parallel one FR107 diode (Equipped in the package) to prevent the self-inductance EMF affect the system, do not reverse the polarities.
  - 3) Each relay may work under the wet mode or dry mode by setting the jumper terminal. If the 12V power supply inside the access controller uses external power supply, the output of each relay is under the "wet mode". If the external power supply uses potential free contacts, the "dry mode" should be used. please refer to Instructions for Hardware of C4-200/400 Access Controller.
- \* It is recommended to short 2-3 ports, the output use the "dry mode", the electronic lock use the external power supply.



- 4) Considering of the consumption of the control panel, the Wiegand reader and the inBIO reader, the standard power supply is 12V/3A. So we don't recommend the lock and the control panel use the common power supply. If it is necessary to use, we suggest to change the bigger one, such as 12V/5A. Except the power consumption reserved, there are 2A current for the lock. For the common electrical lock (the standby current is 300mA, the max current is 500mA), the max connected lock is 2.

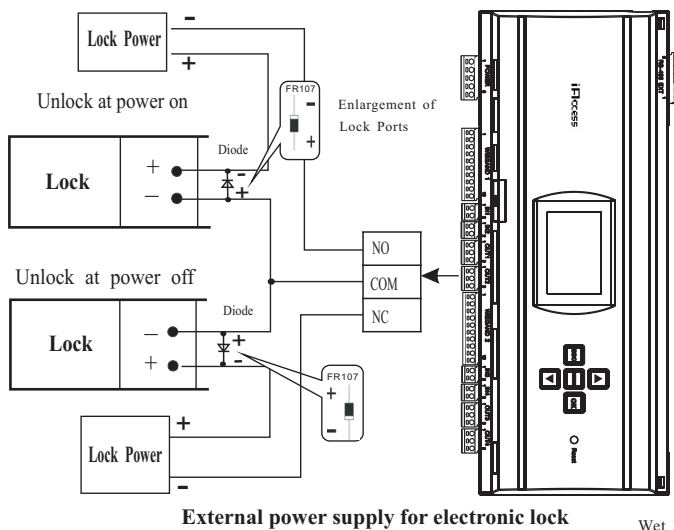

External power supply for electronic lock



Wet Mode:

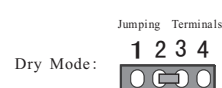

Dry Mode:

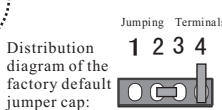

Distribution diagram of the factory default jumper cap:

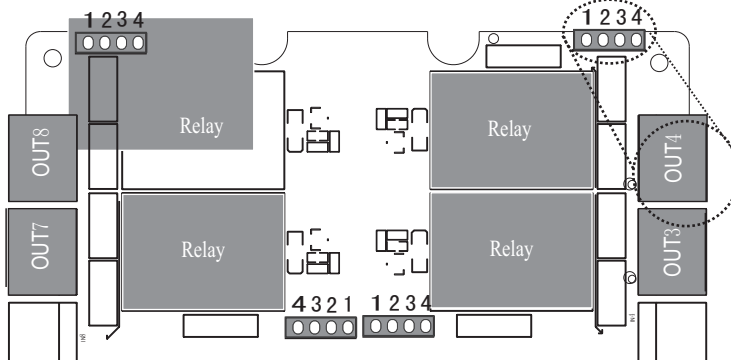

Relay output ports and jumper terminals setting (The second layer of PCB)

**4. 485 Reader (inBIO Reader) Connection**

The control panel supports inBIO biometric verification reader and Wiegand reader. In use of inBIO reader, all operations including storage, verification, etc. execute in control panel. No need to re-register the fingerprints for reader changing. Realize the real biometric reader connection.

**inBIO reader connection:** First of all, set the 485 address (device number) of reader by software, DIP switch or keypad. For reader 1, 2 (the odd number is for enter reader, and the even number is for exit reader), the door number is 1. And the 485 address is 1, 2. Such as the below figure connection. For more information, please refer to the software user manual.

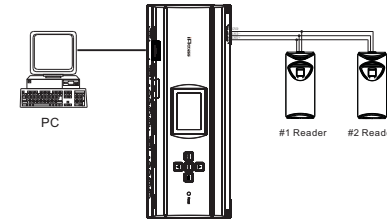

In inBIO reader connection, a single EXT485 interface can supply 500 mA (12V) current at most. So the entire current consumption should be less than this max value when the reader share power with the panel, and put apart enough margin. In calculation, please use the max current of the reader, and the start current is usually more than twice of the normal work current, please consider of this situation.

For example, when you use the F11 reader (the standby current is less than 100mA, the max current is less than 120mA) for inBIO reader connection, the max number is 2 readers. For some of the devices with much bigger consumption, we suggest to use the separately power supply, to make sure the steady operation.

**5. Equipment Communication**

⚠ The PC software communicate with the system through two protocols (RS485 and TCP/IP) for data exchange and remote management. The communication cable should be away from high-voltage lines as far as possible. Do not keep the communication cable in parallel with power cords or bind them together.

1) TCP/IP Mode:

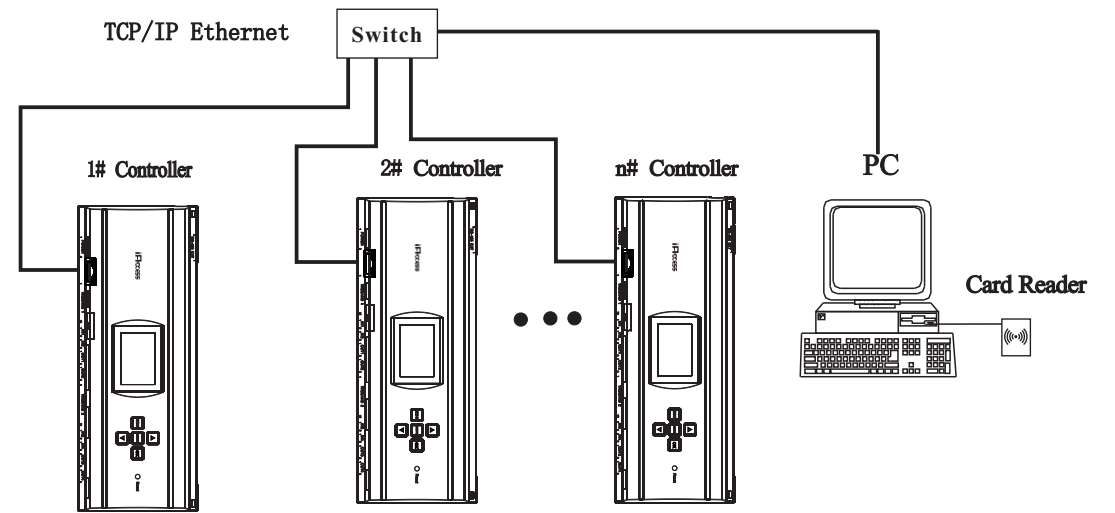

2) RS485 Mode:

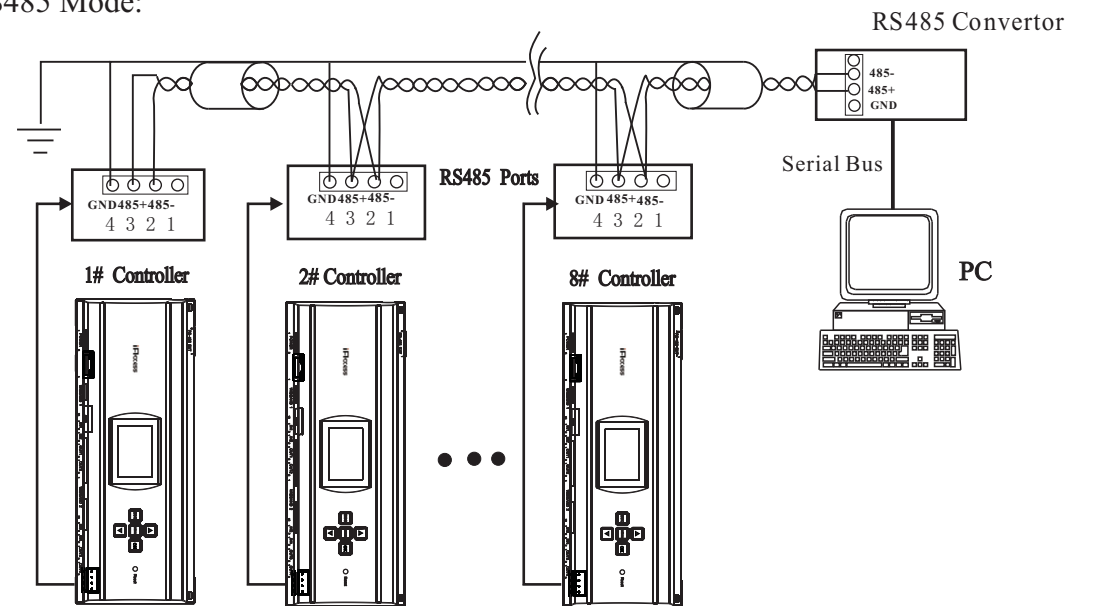

Notes:

- 1) Internationally accepted RVVP (shielded twisted-pair) wires should be used for communication to effectively avoid interference. RS485 communication wires should be connected by means of bus cascade connection.
- 2) Theoretically, in RS485 communication, one bus may be connected with 64 access controllers. It is recommended to connect with no more than 32 devices.
- 3) The recommended bus length of RS485 communication is less than 600 meters.
- 4) When the bus is longer than 300 m, to enhance the stability of communication, it is necessary to change J24 on the first layer of PCB (see the figure below) in the first and the last units (see unit 8# as shown in the figure above) to short pins 2-3. This method is equivalent to connect with a resistance of 120 ohm.

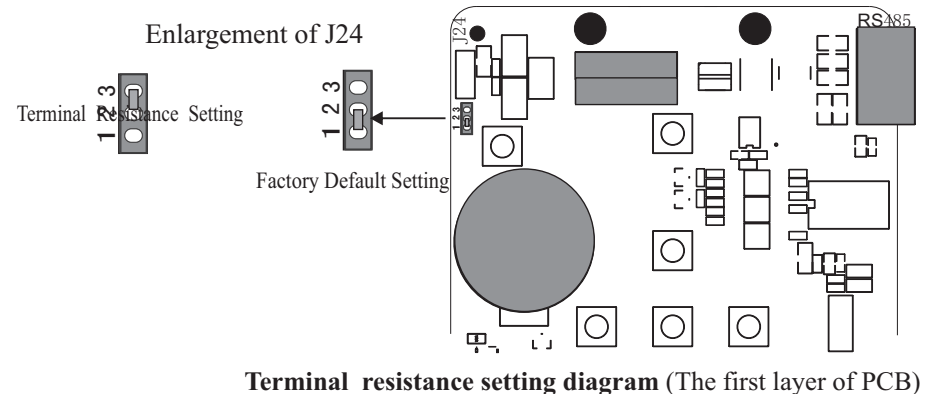

Terminal resistance setting diagram (The first layer of PCB)

## 6. Terminals Connection

Notes:

- 1) The auxiliary input may be connected to infrared body detectors, smoke detectors, gas detectors, window magnetic alarms, wireless exit switches, etc.
- 2) The auxiliary output may be connected to locks, monitors, alarms, door bells, etc.
- 3) The auxiliary input and the auxiliary output via Access Software setting.
- 4) GPRS, WiFi and the following items indicated with "\*" are optional. Please contact our business representatives or pre-sale technical support for ordering machines with GPRS and WiFi functions.
- 5) Recommended use of wires

Interface	Wire specification	Network Cable	Maximum length
Power (A)	18AWG*2PIN	/	1.5M
Wiegand (B)	24AWG*6PIN (6PIN, 8PIN, 10PIN for different readers option)	CAT-5 or above network cable, one way DC impedance less than 100Ω / KM	100M
Electric-lock (C)	18AWG*2PIN+24AWG*2PIN: 118AWG*2PIN for lock connection, 24AWG*2PIN for door sensor connection	/	50M
Power (D)	24AWG*2PIN	/	100M
EXT485 (E)	20AWG*2PIN+24AWG*2PIN: 20AWG*2PIN for reader power supply 24AWG*2PIN for RS485 communication	CAT-5 or above network cable, one way DC impedance less than 100Ω / KM In wire connection, +12V and GND of Power supply need to be parallel and use double wires	Share power with control panel:100M Use readers independence power supply (connect RS485 signal interface only): 1000M

### Front View

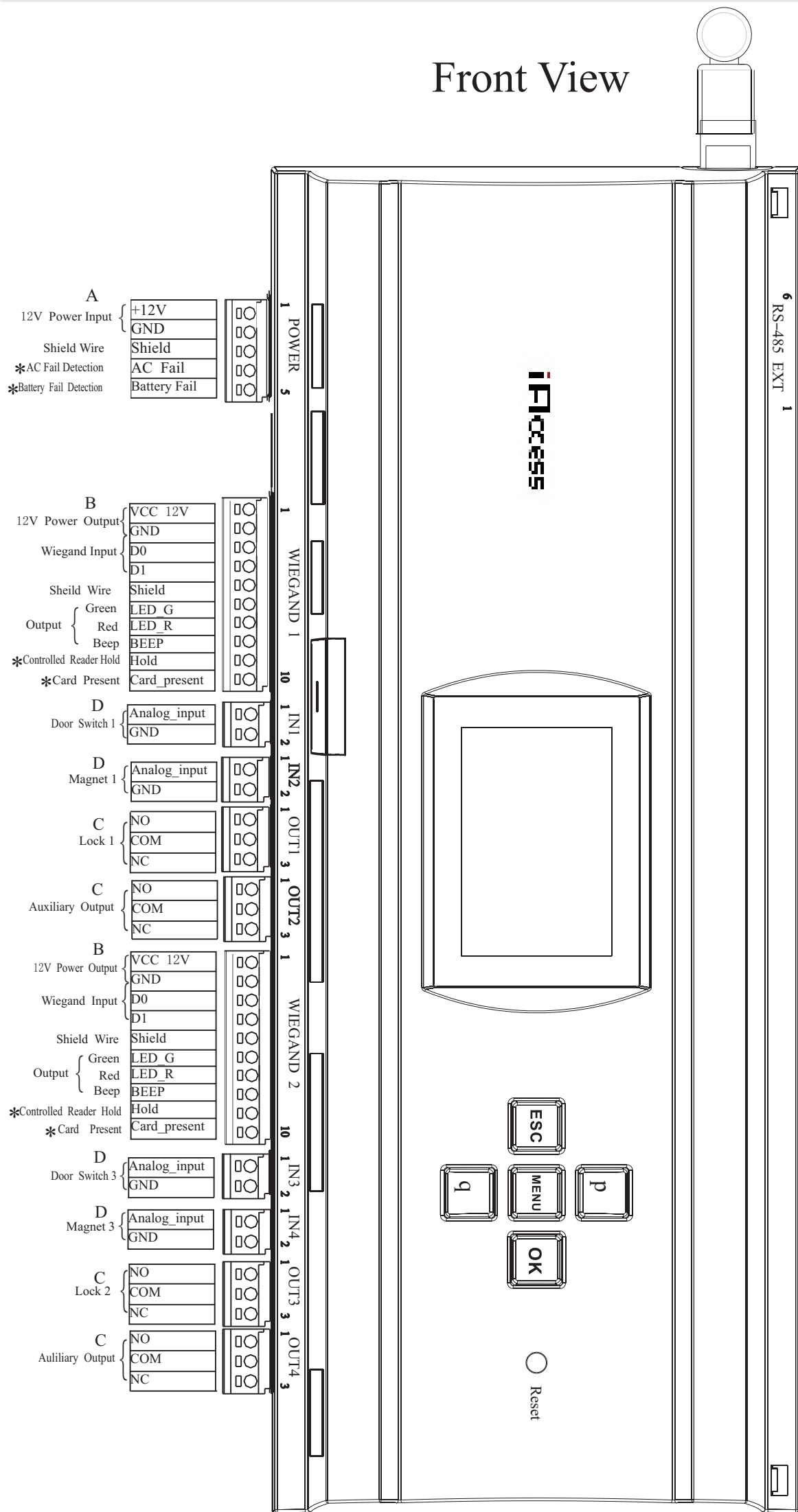

### Front Side View

